

71-8149-250

4/02

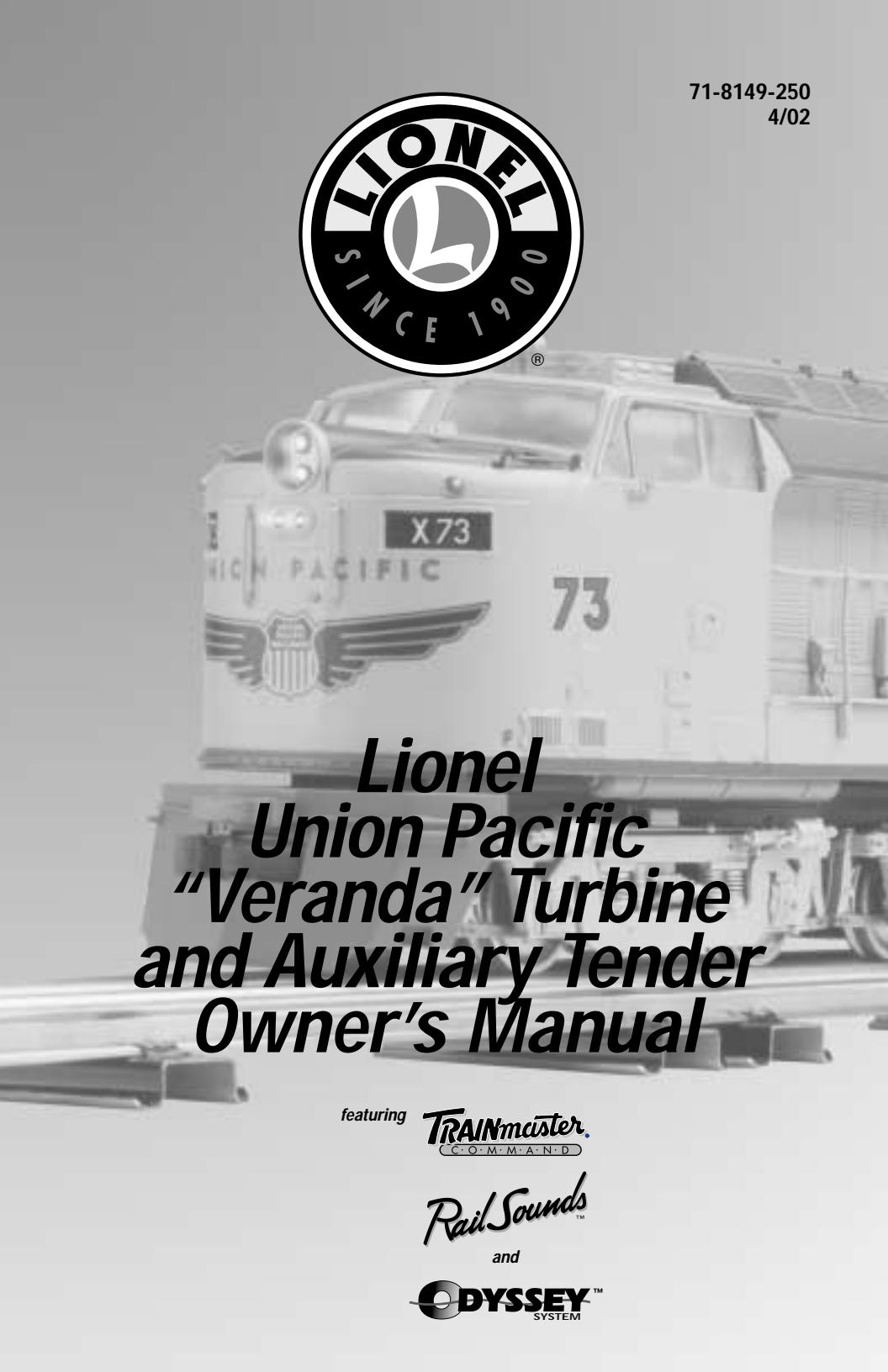

***Lionel
Union Pacific
"Veranda" Turbine
and Auxiliary Tender
Owner's Manual***

featuring

***TRAIN*master.**
C · O · M · M · A · N · D

Rail SoundsTM

and

ODYSSEYTM
SYSTEM

Congratulations!

Congratulations on your purchase of the Lionel Union Pacific “Veranda” Turbine! This durable, die-cast metal locomotive features two Pittman® motors and is equipped with TrainMaster Command Control, the RailSounds sound system, and

the Odyssey System for speed control. The auxiliary tender is also equipped with TrainMaster Command Control for operation of its two ElectroCouplers and back-up light.

Features of the Veranda locomotive

- **TrainMaster Command Control equipped**
- **RailSounds sound system with TowerCom announcements and CrewTalk communication (in Command)**
- **Odyssey System for speed control**
- **Dual high-torque Pittman® motors**
- **ElectroCouplers at the front and rear of the locomotive**
- **Operating headlight, hazard light, directional lighting, and illuminated marker lights**
- **Lighted interior**
- **Dual fan-driven smoke units**

Features of the auxiliary tender

- **ElectroCouplers at the front and rear of the tender**
- **Illuminated back-up light**

The following Lionel marks may be used throughout this instruction manual and are protected under law. All rights reserved.

Lionel®, *TrainMaster®*, *Odyssey®*, *RailSounds™*, *CrewTalk™*, *TowerCom™*, *DynaChuff™*, *StationSounds™*, *Pullmor®*, *ElectroCoupler™*, *Magne-Traction®*, *CAB-1 Remote Controller®*, *Powermaster®*, *Lionel ZW®*, *ZW®*

Table of contents

Transformer operations

Running your Veranda with a Lionel transformer	4
Locking your Veranda into a single operational state	5
Using your Veranda's ElectroCouplers in the non-Command environment	6
Installing a Lionel Sound Activation Button	7

Odyssey System operations

The Odyssey System	8
Odyssey System conventional (transformer) operation	8
Odyssey System Command operation	9

RailSounds operations

Your Veranda's RailSounds system—the basics	10
Experiencing the range of your Veranda's RailSounds system	11
Notes on RailSounds	11

TrainMaster Command operations

The Command Control environment	12
Running your Veranda in the TrainMasterCommand environment	13
CAB-1 commands for your Veranda	13
CAB-1 numeric keypad commands for your Veranda	14
Tuning your Veranda's performance	15
Assigning your Veranda a new ID#	16
Building a lash-up	17
Reprogramming the Command reverse unit to restore features	18

Maintaining and servicing your Veranda

Lubricating your Veranda	19
Operating your Veranda's smoke generators	20
Command Control smoke unit commands	20
Replacing the Traction Tires	21
Replacing your locomotive's lamps	22-23
Caring for your locomotive and tender antennas	23
Lionel Service	24

Transformer operations

Running your Veranda with a Lionel transformer

1

Place your Veranda locomotive on Lionel or Lionel-compatible 0 gauge track with a diameter of 72" or larger.

- **If you are operating your locomotive with the auxiliary tender,** place the tender on the track behind the locomotive with the back-up light at the rear.

2

Power up your Veranda with your transformer.

- **The red hazard light will illuminate at the front of your locomotive.** The locomotive is in neutral.
- **Your Veranda is designed to operate on 8-18 volts alternating current.** Virtually all Lionel and Lionel-compatible alternating-current transformers are suitable.

Caution!

Do not power your Veranda with direct current (DC). Damage to sensitive electronic components may occur.

Note!

When you first power up your track, the Veranda will wait between three and eight seconds as it "listens" for digital language from the TrainMaster Command Base (available separately). When it's determined that it's on a conventional (non-Command) railroad, the Veranda's headlight will illuminate and RailSounds will fire up. At this point, the Veranda is in neutral. (This occurs when placing the Veranda on your railroad for the first time. Thereafter, it will start in forward following every three-second power interruption.)

3

Move 'em out!

- **Get your Veranda moving.** Press the DIRECTION button on your CAB-1 remote or Lionel transformer. This sequences the Command reverse unit to the next operating state.
- **When your locomotive begins to move,** the Mars light will illuminate and the red hazard light will turn off on the front of your locomotive. The Mars light is on only when the locomotive is in motion. The hazard light is on only when the locomotive is in neutral.
- **Adjust track voltage** until the Veranda moves at your desired speed. To increase speed, increase track voltage. To decrease speed, reduce voltage. To stop the locomotive, turn off track power.
- **See page 5 for information on locking your Veranda in a single operational state.**

Transformer operations

Locking your Veranda into a single operational state

To select a single operational state for your Lionel Veranda (example: forward only), you can deactivate the Command reverse unit's sequencing function with the Command reverse unit switch.

Get your locomotive moving in your desired direction, then *slow it down without stopping*. Set the Command reverse unit switch to PROG. Refer to Figure 1 for the location of the switch. The Veranda is

now "locked" into your chosen direction.

When you no longer want single-direction operation, just slide the Command reverse unit switch back to RUN.

Note! Your locomotive's reverse unit will "reset" to forward after any five second or longer power interruption, regardless of the original locked-out direction.

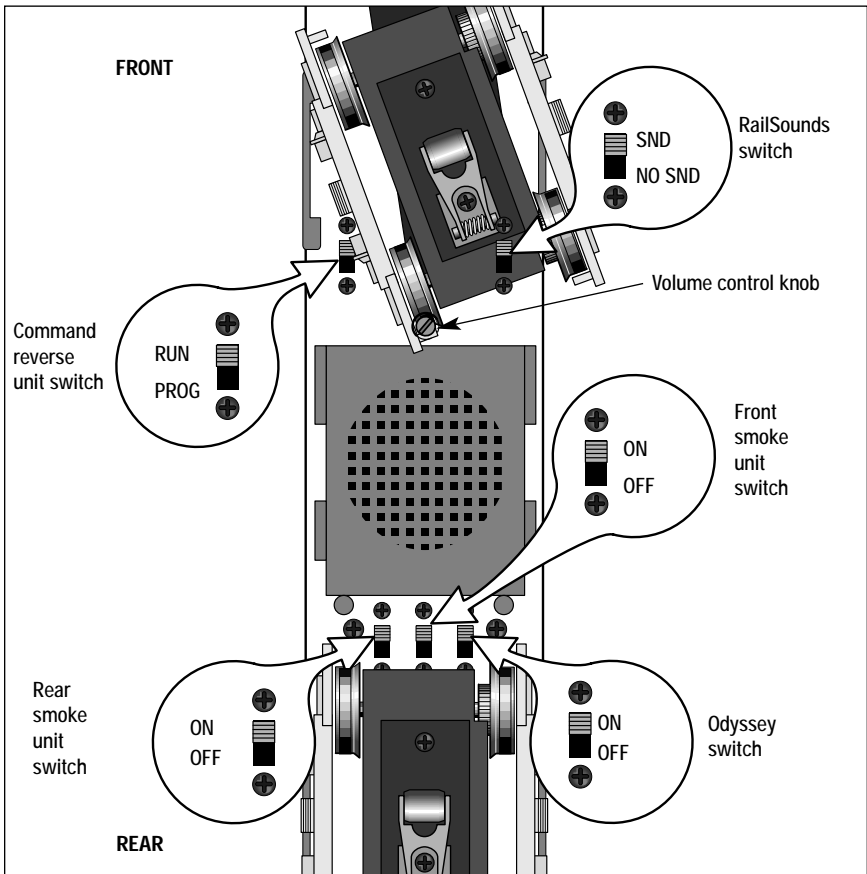

Figure 1. Switch locations on the locomotive

Transformer operations

Using your Veranda's ElectroCouplers in the non-Command environment

To uncouple rolling stock from your ElectroCouplers on the Veranda or the tender in the non-Command environment, you must rely on a piece of rolling stock equipped with Lionel magnetic couplers coupled directly to your ElectroCouplers. The magnetic coupler on the rolling stock will then react to the magnetic field generated by

a Lionel Remote-Control Track section (available separately, 6-65530 for O gauge, 6-65149 or 6-12746 for O-27 gauge). Place your rolling stock's coupler "trigger disc" over the central coil of a Remote-Control Track section and press UNCOUPLE on the controller. The magnetic field pulls the disc downward, and the coupler opens.

Note! The ElectroCouplers will NOT open manually or by using a Remote-Control Track section.

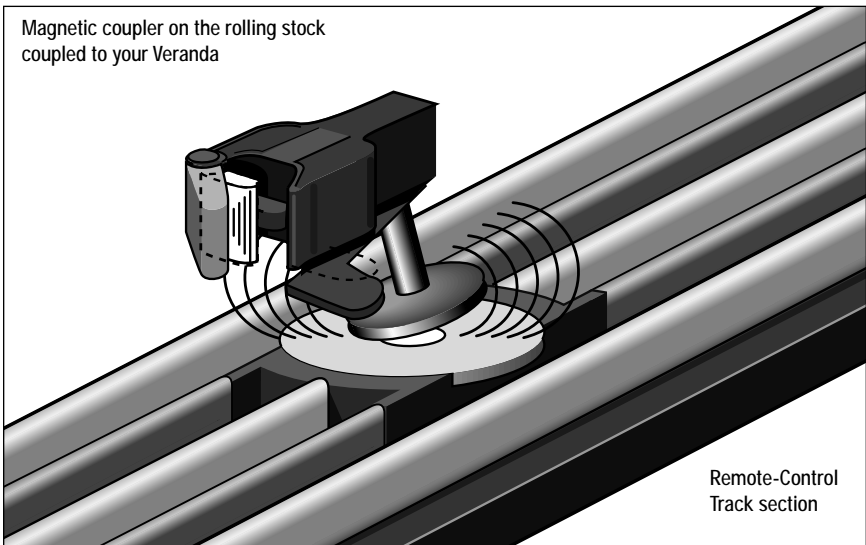

Figure 2. Trigger disc operation

Transformer operations

Installing a Lionel Sound Activation Button

To operate the bell and horn sounds when operating your locomotive with conventional transformers, you'll need to install a Lionel no. 610-5906-001 Sound Activation Button (available separately).

Connect the button(s) as shown below.

Note! All track power must feed through the Sound Activation Button. Do not bypass the button.

For AC transformers with a horn/whistle button

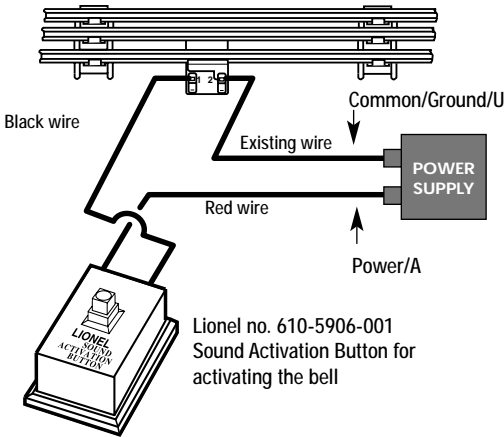

For AC transformers lacking a horn/whistle button

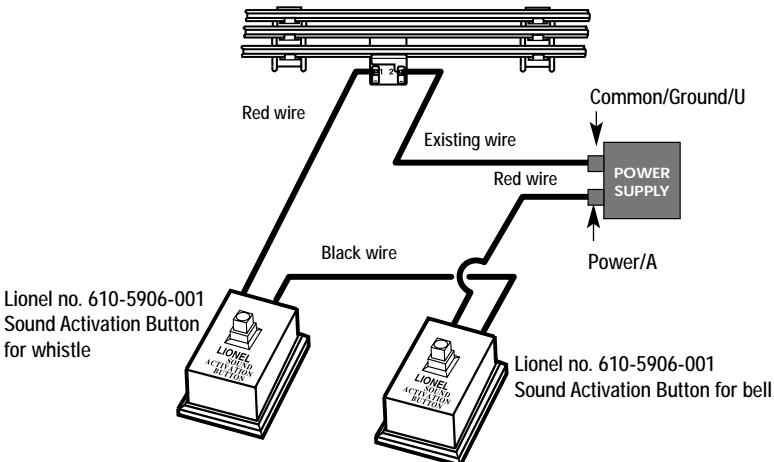

Note!

The no. 610-5906-001 button works with any Lionel AC transformer except no. 6-4690 Type MW. Transformers made by other manufacturers may not be compatible with RailSounds.

Odyssey System operations

The Odyssey System

The Odyssey System is a “cruise control” for your engine. This digitally-controlled system allows for extremely slow movement that will amaze any “scale” enthusiast. Because your Veranda’s wheels roll freely, you may notice an increase in

speed as the locomotive travels down the grade, depending on the load and the steepness of the grade. You may also notice a slight reduction in speed as the locomotive ascends the grade.

Odyssey System conventional (transformer) operation

Setting Speed Control

1. Run the engine at the desired speed for approximately five seconds. Be sure the Odyssey switch is in the ON position. See page 5 for the switch locations.
2. Press and hold the horn button.
3. While holding the horn button, increase the track voltage by at least three volts (at least 1/4 turn).
4. At this point, speed control is set.

Note! Engine speed will increase slightly before returning to the set speed.

Turning off Speed Control using your transformer:

1. While the engine is in neutral, turn your controller up to the maximum power (no more than 20 volts), wait one second, then press and hold the horn button.
2. While holding the horn button, slowly reduce track voltage to one-fourth of full power. The marker lights will turn off. Keep reducing the throttle and the marker light will turn on.
3. Release the horn button.
4. Cycle the engine to forward/reverse. The engine is now out of speed control mode.

Caution! In conventional operation, the lights in both the engine and tender are connected directly to track power. Do not exceed 14-16 volts for extended periods. Doing so will reduce the life of your lamps.

Note! If you experience problems with speed control, turn off track power, place the locomotive on the track with the Odyssey switch OFF, and throttle up. This will clear the speed settings. You must slide the switch back to the ON position to set another speed setting.

Odyssey System operations

Odyssey System Command operation

Use your CAB-1 remote to turn the Odyssey System speed control on or off. The marker lights will flash twice after each sequence has been entered. **The Odyssey switch position (see page 5) is the Odyssey system default setting when**

you power up the locomotive. You may override the default with the following commands. The override settings will be cleared and the default settings will be restored when the locomotive is powered down.



Turns off Odyssey System speed control
Marker lights blink twice



Turns on Odyssey System speed control
Marker lights blink twice

Do not wait longer than two-three seconds between pushing the buttons in each sequence. If the command is not accepted, repeat the sequence.

Note! The locomotive must be in “neutral” while enabling or disabling the Odyssey System speed control.

RailSounds operations

Your Veranda's RailSounds system—the basics

Lionel RailSounds is the most realistic model railroad sound system in the world. Your Veranda features diesels sounds at low speeds and turbine sounds as the speed increases.

As illustrated in Figure 3, you may choose to install a 9-volt *alkaline* battery in your Veranda. This ensures interruption-free operation of RailSounds. Remove the six body screws illustrated in Figure 5 on page 19. The battery clip is located inside the body toward the rear of the locomotive.

Attach the battery harness, slide the battery into the holder, and replace the body.

When you first apply track power, the Veranda's RailSounds system produces sounds of the locomotive at rest. As the Veranda moves, the RPM's increase with the locomotive's speed.

To silence the sounds (the horn and bell remain unaffected), slide the RailSounds switch on the underside of the locomotive to NO SND (refer to Figure 1 on page 5) *before powering up the locomotive*.

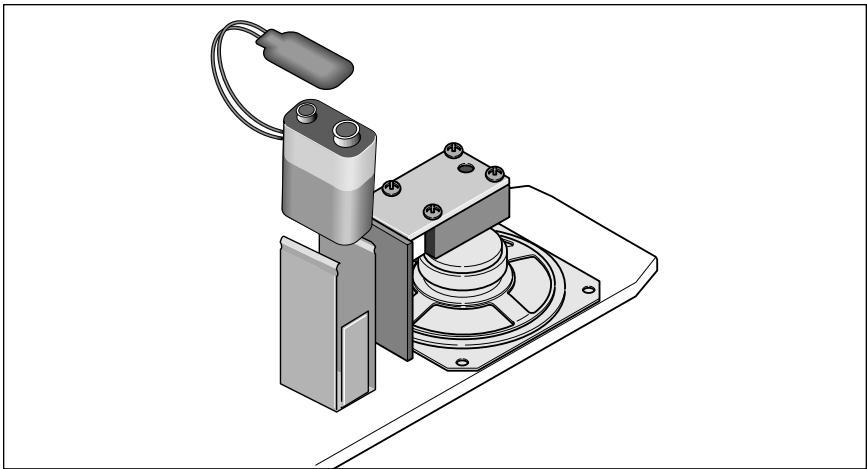

Figure 3. Battery installation

Note! Please remove the protective cover from the battery clip.

Note! Although RailSounds is powered by track voltage, the *battery is required* for uninterrupted operation and shutdown sequences. Use only alkaline batteries.

Note! Discontinue locomotive power *for 10 seconds* before changing the RailSounds SND/NO SND switch position.

Note! If RailSounds “drops out” during track power interruptions (for example, during a direction change), replace the battery.

RailSounds operations

Experiencing the range of your Veranda's RailSounds system

With RailSounds, you experience the sounds of real railroading like never before. Simply put, it's the most sophisticated, authentic model railroad sound system in the world.

- **Diesel and turbine sounds.** Your Veranda features diesel sounds at low speeds and turbine sounds as the speed increases.
- **MultiHorn.** A different horn sound at different speeds—a RailSounds exclusive.
- **Mechanical bell.** Press BELL on your CAB-1 or transformer to begin the effect, again to discontinue.
- **Reverse unit reset sound.** Power down your track, wait for 3-5 seconds, and listen for the air-release sound—that's the Veranda telling you its Lionel Command reverse unit has just *reset to forward operation*.
- **Shutdown sequence.** No other model railroad sound system shuts down like RailSounds. Turn off track power, and after the air-release reset sound, you have two seconds to restart your Veranda. If you're done with operations, RailSounds will commence with a realistic shutdown sequence about two seconds after the air-release reset occurs. (Battery installation required.)

Notes on RailSounds

- Turn the volume knob clockwise or counter-clockwise in the location shown on page 5 to adjust sound output.
- Listen for incidental locomotive sounds during RailSounds operation. They're automatic and, of course, authentic.
- The 9-volt alkaline battery you installed ensures *continuous* sounds.
- Longer track-power interruptions (including locomotive derailments) cause RailSounds to shut down after about seven seconds.
- For even *more* authentic RailSounds effects, operate in the TrainMaster Command environment.

TrainMaster Command operations

The Command Control environment

Lionel TrainMaster Command Control is the advanced model railroad control system from Lionel. TrainMaster Command Control gives you the power to operate multiple Command-equipped locomotives *on*

the same track, at the same time.

To operate in Command mode, you need a Command Base and a CAB-1 remote. Find them both at your authorized Lionel retailer.

1

Place your Veranda on Lionel or Lionel-compatible O gauge track with a diameter of 72" or larger.

- **Make sure track power is OFF before placing the locomotive and tender on the track.**
- **If you are operating your locomotive with the auxiliary tender,** couple the tender to the rear locomotive coupler with the back-up light pointing to the rear.
- **Make sure your Lionel Command Base is plugged-in** and its communications wire is connected to the COMMON post on your Lionel transformer *or* the U terminal on any of your installed PowerMasters.
- Once positioned on the track, **increase track voltage to FULL** (no more than 20 volts). On PowerMasters, slide the CMD/CONV switch to CMD.

2

Address your Veranda using CAB-1.

- **Your Veranda and auxiliary tender come factory-programmed as a lash-up with a train (TR) ID# of "9."** The Veranda is factory-programmed as engine (ENG) ID# 1; the tender is engine (ENG) ID# 2. To change the ID#'s, see page 16.
- **Press TR and 9** on the numeric keypad of your CAB-1 remote to address both the Veranda and the tender as a lash-up. This command is sent by CAB-1 to the Command Base, which then translates your command into digital code. That code is sent around your railroad's outside rails in the form of a digital "halo." All Command-equipped Lionel engines listen to this digital communication.
- **The digital language of TrainMaster Command—and not track power—controls the actions of Command-equipped Lionel engines.** Track power is simply like gasoline in the tank of your car—it gives you the power to go places, but it doesn't tell you where to go or how fast to get there.

3

Move 'em out!

- Throttle up or press any command button on CAB-1. Your Veranda will respond to your every command. Read on.

TrainMaster Command operations

Running your Veranda in the TrainMaster Command environment

Example Address Locomotive #1

PowerMasters set to CMD or traditional power supplies ON FULL (no more than 20 volts)



Press ENG



Press 1 (the ID#)

Throttle up/press any command button

Your Command-equipped Veranda comes factory-programmed with an ID# of “1.” To operate your Veranda (without the tender), set PowerMasters to CMD or set all power supplies on full (no more than 20 volts). Press ENG and “1” on your CAB-1. Turn the throttle or press any command button; your Veranda is ready for Command operations.

Note! To operate the Veranda and the tender in a lash-up, see page 17.

CAB-1 commands for your Veranda

COUPLER



Front coupler releases locomotive or tender. **Coupler release sounds.**

COUPLER



Rear coupler releases locomotive or tender. **Coupler release sounds.**

AUX 1



Activates the keypad.

AUX 2



Press AUX2 to turn your Veranda's headlights on and off.



Turn the THROTTLE to the right to accelerate, left to decelerate.



Press HALT to shut down all PowerMaster electrical output on your railroad. Stops all Command-equipped Lionels in operation.



Press WSTL/HRN to activate the Veranda's horn, release it to discontinue. **MultiHorn horn sound.**



Press BELL once to activate the bell, again to discontinue. **Mechanical bell sound.**



Press DIR—the locomotive decelerates to a complete stop; turn the throttle up, and the locomotive will accelerate in the new, opposite direction. THERE IS NO NEUTRAL STATE. **Air-release sound.**



Press and hold BOOST for extra power. Release BOOST and return to the Veranda's previous speed.



Press and hold BRAKE to slow down or stop. Release BRAKE and return to the previous speed. **Squealing brake sounds.**

Note! Use HALT only in emergency situations.

Beneath this panel



TrainMaster Command operations

CAB-1 numeric keypad commands for your Veranda

When you press AUX1 on your CAB-1, you turn the numeric keypad into ten command buttons. The keypad lets you control extra command features (until you press any top-row button like SW, ACC, RTE, TR, or ENG). ***RailSounds sounds in bold italic.***

Note! Locomotive features and responses are listed, unless the tender is noted.

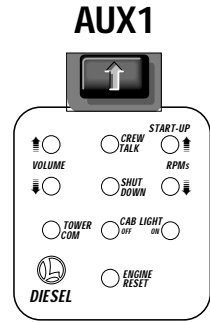

0 Stops and resets the Veranda. Resets the Veranda's direction to FORWARD. Resets RailSounds to automatic RPM operation. ***Horn blows. RPMs return to automatic.***

1 Raises the volume of RailSounds. ***Sound volume increases.***

2 ***CrewTalk*** is the sound of unintelligible walkie-talkie communication.

3 Starts-up RailSounds or raises RailSounds RPM level. ***Start-up sequence commences. RPMs increase.***

4 Lowers the volume of RailSounds. ***Sound volume decreases.***

5 Activates the RailSounds shutdown sequence. Just like the real thing, *your Veranda must be at idle for shutdown to occur.* Press 6 repeatedly to lower the RPM's until they won't descend further. Your locomotive is now at idle. Press 5 to initiate the

shutdown sequence, and listen for the CrewTalk sound. ***CrewTalk sounds, Shutdown commences.*** Remember, the horn, bell, and RPM's will not sound until you *restart* RailSounds by pressing 3.

6 Lowers RailSounds RPM level. ***RPMs decrease.***

7 ***TowerCom*** is an audible two-part announcement that includes that locomotive's road number and/or name. Pressing 7 the first time triggers a "Hold for clearance" announcement. Press 7 again, and a "Clear for departure" message plays. There is a four second delay in this function.

8 Turns the cab light off. ***Air-release sound.***

9 Turns the cab light on. ***Air-release sound.***

Note! See page 20 for smoke ON/OFF commands.

TrainMaster Command operations

Tuning your Veranda's performance

MOMENTUM

The momentum feature simulates the labored performance of a locomotive pulling a heavy load. Press L, M, or H (located under CAB-1's removable panel) for light, medium, or heavy momentum. The Veranda's Command reverse unit remembers this setting until you change it. For quick locomotive response, choose L.

BRAKING AND BOOSTING

There's more to starting and stopping than just turning the CAB-1 throttle. Use the BOOST and BRAKE command buttons—they give you incremental control of speed *and* are the superior way to handle grades, gradual stops-and-starts, and more. Plus, using BRAKE in the Command environment gives you a bonus RailSounds effect—the ultra-realistic sound of squealing brakes.

SOUND QUALITY

To achieve your preferred RailSounds master volume level, we recommend that you adjust your Veranda volume control knob (see page 5 for the location). Turn the knob left or right to reach the desired volume level.

For quick remote-control of volume

below the master setting—for example, muting—use the CAB-1 numeric keypad's volume control. Press AUX1 and then 4 on the numeric keypad to lower the overall RailSounds output.

HIGH VOLTAGE SETTING

Press SET, and the headlight will flash. Get your locomotive moving to the maximum speed you want it to run, then press BOOST. Use this to keep your locomotive from derailing at excessive speeds. Turn off the high voltage setting by pressing SET, then BOOST, holding each for one second.

STALL

Make your Veranda feel more responsive by setting a “stall” voltage. Get your locomotive moving, then press SET; the Veranda will stop. Turn the throttle clockwise to get the locomotive moving, then decrease speed until the locomotive just stops. Press SET again; the Command reverse unit remembers the stall setting until you change it. To clear the stall setting, press SET twice, holding it for one second each time.

Note! These settings will be lost when you assign a new engine ID#.

TrainMaster Command operations

Assigning your Veranda a new ID#

Example Assign a new ID# to your Command-equipped Veranda

Set the Veranda Command reverse unit switch to PROG

Command Base plugged in

Place the Veranda on track

PowerMasters set to CMD or traditional power supplies ON FULL (no more than 20 volts)

Turn track power on (PowerMasters):



Press BOOST

Program the Veranda with a new ID#:



Press ENG



Press a number you choose (the ID#)



Press SET

Set the Command reverse unit switch to RUN

Your Veranda remembers its ID# forever; change it any time with these steps

We recommend that you choose an easy to remember ID# for your engine. Some possibilities are part of the engine road number, your age, or any two digit number that is not used by another engine. Write the number on a small piece of tape and put this on the bottom of the fuel tank to aid in remembering.

While your Veranda and tender have been factory-programmed as a lash-up, both units must have their own ID#'s. This allows you to open the appropriate ElectroCouplers and set the appropriate directional lighting. The Veranda has been assigned ID# 1; the tender has been assigned ID# 2.

To change these individual ID#'s, switch the Command reverse unit switch to PROG on either the Veranda OR the tender. Do not attempt to assign both ID#'s together. Refer to Figure 1 on page 5 for the locomotive switch location. Refer to Figure 4 below for the tender switch location. Plug in the Command Base, set the unit on the track, then power up. Using your CAB-1 Remote Controller, press ENG, enter your ID# (between 1 and 99), then press the SET button located under the removable panel on the CAB-1 Remote Controller.

The Command reverse unit will confirm the new ID#. On the Veranda, the headlight will flash. Once you see this signal, you know that your new ID# has been programmed. Slide the reverse unit switch back to RUN.

Note! If you change the ID# of either the Veranda or the tender, you must build a new lash-up to control both units together.

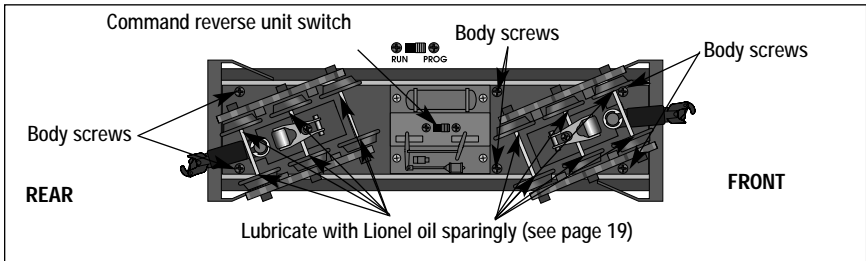

Figure 4. Tender switch location and lubrication points

TrainMaster Command operations

Building a lash-up

Your Veranda and tender were factory-programmed as a lash-up. When you press TR, 9 on the CAB-1 Remote Controller, both units respond together, allowing the headlight and back-up lights to work together. Remember, you can always address an individual unit in a lash-up using its ENG ID#.

You will need to build a new lash-up if you want to change the lash-up (TR) ID#, add an additional locomotive, or assign new individual ID#'s to any part of the consist.

To build a lash-up, assign a unique engine (ENG) ID# to both units. Arrange the units on the track and couple them together. The Command reverse unit switches must be set to RUN/FORWARD.

Note! If you press a wrong button, start over with that particular unit; the assignment isn't saved until you press SET on the CAB-1.

Start with the Veranda.

1. On your CAB-1 remote controller, press TR, then enter your lash-up ID# (1-9).

Note! No other track or lash-up should be assigned that ID#.

2. Enter the lead unit's unique ID#, then press F.
3. Press SET beneath the front panel of the CAB-1.

The HORN will blow to indicate that the lead locomotive has been assigned the first position.

Complete the lash-up by adding the tender:

1. On your CAB-1 remote controller, press TR, then enter your lash-up ID# (1-9).
2. Enter the last unit's unique ID#, then press R.

Note! It is not necessary to press the DIRECTION button.

3. Press SET beneath the front panel of the CAB-1.

TrainMaster Command operations

Reprogramming the Command reverse unit to restore features

Due to the inevitable derailments and static, it is possible that the Command reverse unit in the locomotive or the tender could someday lose its setup program. The symptom of this condition would be unresponsiveness in Command mode. This can be easily remedied by “reprogramming” your Command reverse unit using the following steps.

STEP 1: Move the switch on your unit from RUN to PROG.

STEP 2: Plug in your Command Base.

STEP 3: Place the unit on track, then turn on power to your track.

STEP 4: Press “ENG” then input the unit’s ID#. Press “SET.”

STEP 5: Press “ENG,” the ID#, “AUX1,” then press **6** for your Veranda or tender.

STEP 6: Turn off power to your track and wait ten seconds.

STEP 7: Remove the unit from your track, and move the switch from PROG to RUN.

STEP 8: Place the unit back on track, then turn on power to the track.

STEP 9: Press “ENG” and the ID#, then operate as normal.

Maintaining and servicing your Veranda

Lubricating your Veranda

Help your Lionel Veranda lead a long and productive life on your railroad by maintaining it properly.

We recommend that you purchase a Lionel Lubrication and Maintenance Kit (no. 6-62927), available from your Lionel dealer. Two basic rules to keep in mind: *never* over-lubricate (a small amount will do), and avoid getting grease or oil on the Veranda's wheels *or* your track. You'll know your Veranda requires lubrication when visual inspection reveals dryness on the parts indicated in Figure 4 on page 16 and Figure 5. Remove accumulated dirt and dust before lubricating, and always lubricate any locomotive emerging from prolonged storage.

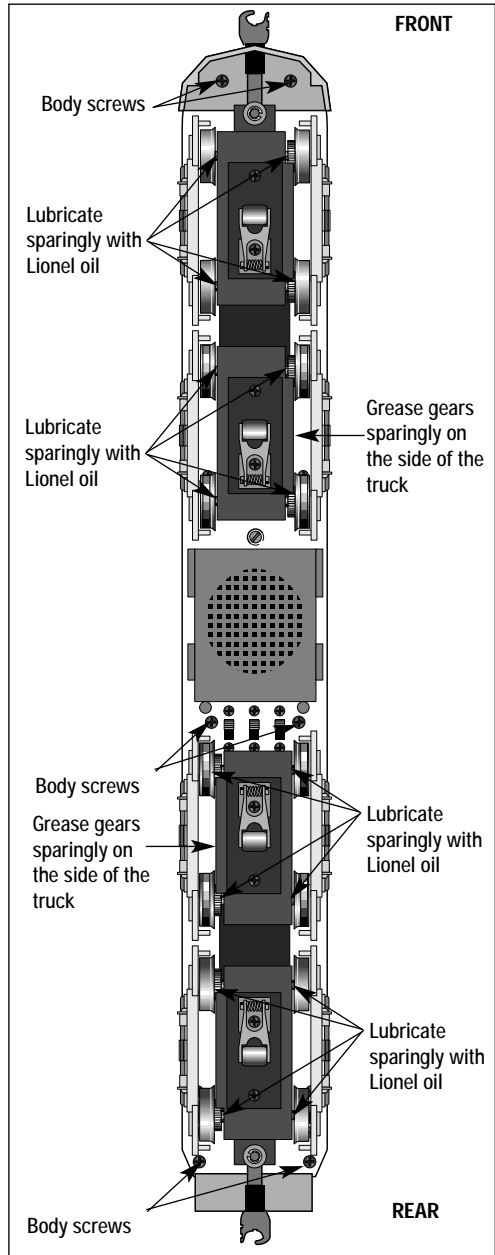

Figure 5. Underside details and lubrication points

Maintaining and servicing your Veranda

Operating your Veranda's smoke generators

Your locomotive is equipped with two smoke generators that produce safe, clean, white smoke during operation.

The smoke generators require the periodic addition of Lionel smoke fluid in order to function. Pierce the tube end with a pin, then add no more than 15 drops of fluid into the locomotive's stacks. Adding more fluid will not increase the production of smoke. See Figure 6 for the location of the smoke stacks. It is important to add fluid to the square stack above the rear smoke generator to prevent flooding the interior of your locomotive. Smoke production will commence momentarily. When smoke production wanes, add more fluid (four to eight drops).

If you prefer to have a smoke-free locomotive, there are two smoke unit switches located on the bottom of the engine (see page 5 for their locations). Move the

switches to OFF and your locomotive will stop smoking.

When the smoke units are on, *always* keep a small amount of smoke fluid in the locomotive's smoke generators; the elements can become damaged if operated without fluid.

Command operation

Your Veranda's smoke units mimic the operations of the real thing. The rear smoke unit will heat up in approximately 30 seconds, then it will turn on. As the speed increases, the forward smoke unit will turn on, and the rear smoke unit will turn off.

Conventional operation

During operation, both smoke units will remain on, regardless of the speed of the locomotive. You may use the smoke unit switches to turn off either smoke unit or both smoke units.

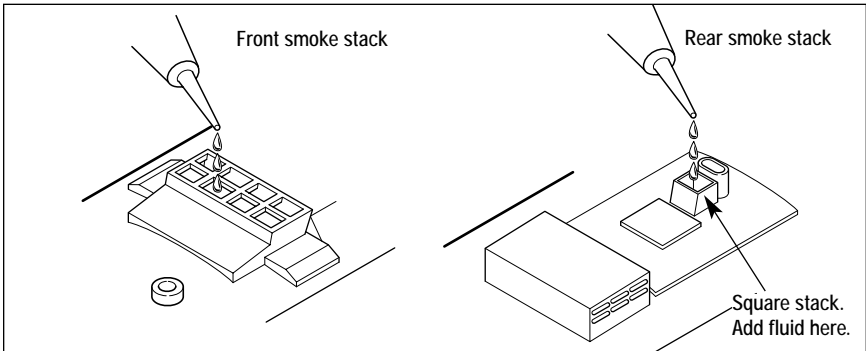

Figure 6. Stack locations

Command Control smoke unit commands



Rear smoke unit OFF. Repeat to turn ON.



Front smoke unit fan OFF. Repeat to turn ON.



Front smoke unit element OFF. Repeat to turn ON.

Maintaining and servicing your Veranda

Replacing the Traction Tires

Your locomotive is equipped with eight Traction Tires. These tires increase the tractive effort of your locomotive, allowing it to pull more cars at once. During the course of normal operation, the Traction Tires may become worn out.

To replace the Traction Tires, remove the six body screws that secure the cab to the frame. Refer to Figure 5 on page 19. As illustrated in Figure 7 below, turn the locomotive upside-down and remove the screw from the underside of the truck. Be sure to support the motor when the screw is

removed. Removing this screw will release the motor, allowing you to flip over the truck. Be sure that the wires attached to the trucks are not disconnected. Remove the two frame mounting screws that secure the side frame to the truck. Slip off and replace the Traction Tire. Before you reassemble the truck, you may grease the gears that are found on the top of the truck. Follow these steps in reverse order to reassemble the locomotive. After you have repositioned the motor on the truck, rotate the flywheel by hand to be sure that the gears turn freely.

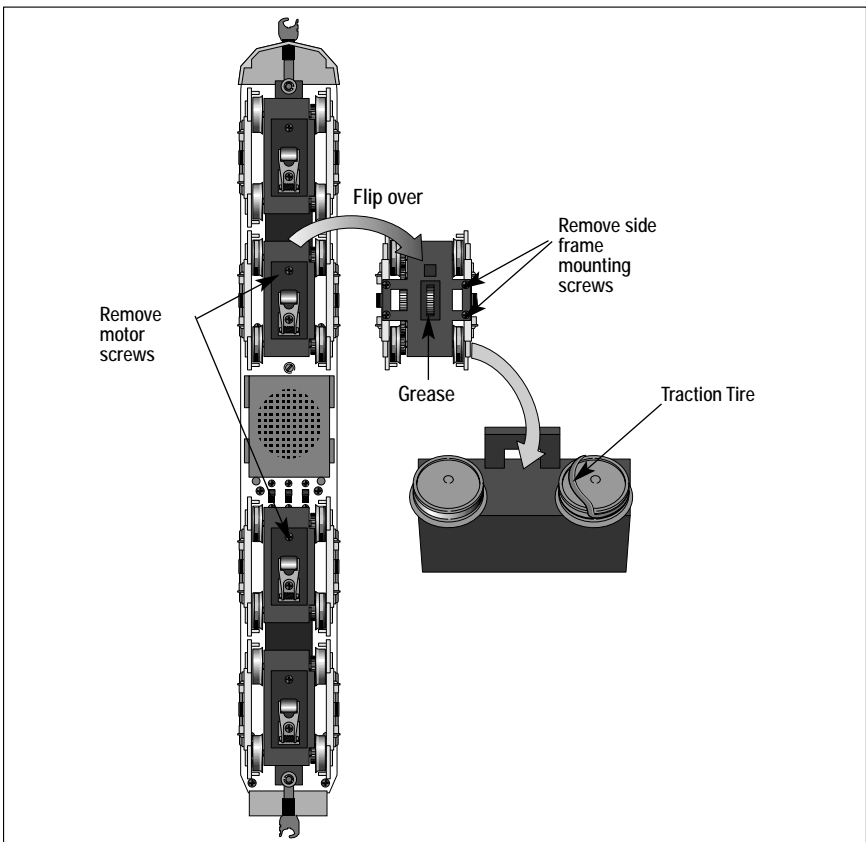

Figure 7. Traction Tire replacement

Maintaining and servicing your Veranda

Replacing your locomotive's lamps

Your locomotive is illuminated by several lamps and LEDs. To replace these components, begin by removing the six cab screws. Refer to Figure 5 on page 19 for their locations. Locate the expired lamp or LED and carefully slide it out of its housing. Detach the expired lamp by unplugging the connector. See Figure 8 below. Listed below

in Table 1 are the part numbers for the various locomotive lamps and LED's. Be sure that the wires are not pinched when you replace the cab.

Note! Do not remove any of the handrails or other details when changing the bulbs or LED's.

Cab interior light	610-8149-300
Mars light	610-8149-310
Hazard light	610-8149-320
Marker lights	610-8149-330
Number boards	610-8149-340
Back-up light	610-8149-350

Table 1. Replacement lamp and LED part numbers

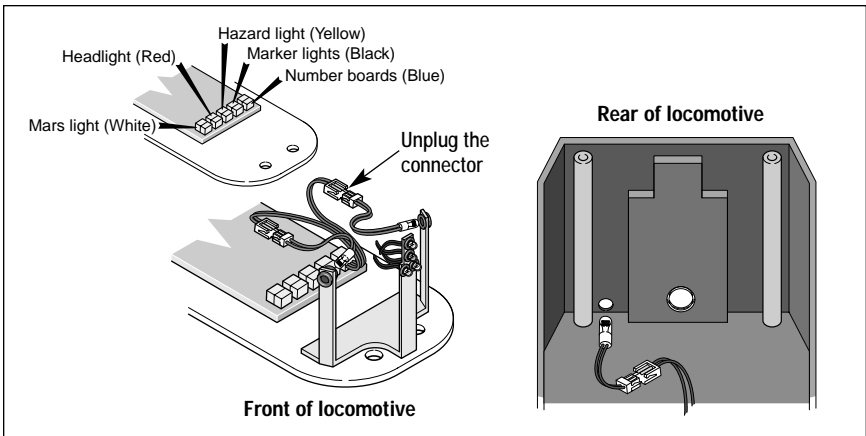

Figure 8. Locomotive lamp replacement

Note! Press AUX2 on your CAB-1 to make sure that the lamps and LED's were not accidentally turned off.

Maintaining and servicing your Veranda

Replacing your locomotive's lamps (continued)

The back-up light on the auxiliary tender is illuminated by one lamp. To replace the lamp, remove the six body screws. See Figure 4 on page 16. Remove the small screw beneath the back-up light as

illustrated in Figure 9 below. Slide the expired lamp out of the housing. Separate the connector, then install the new lamp, part no. 610-8149-360. Reassemble in reverse order.

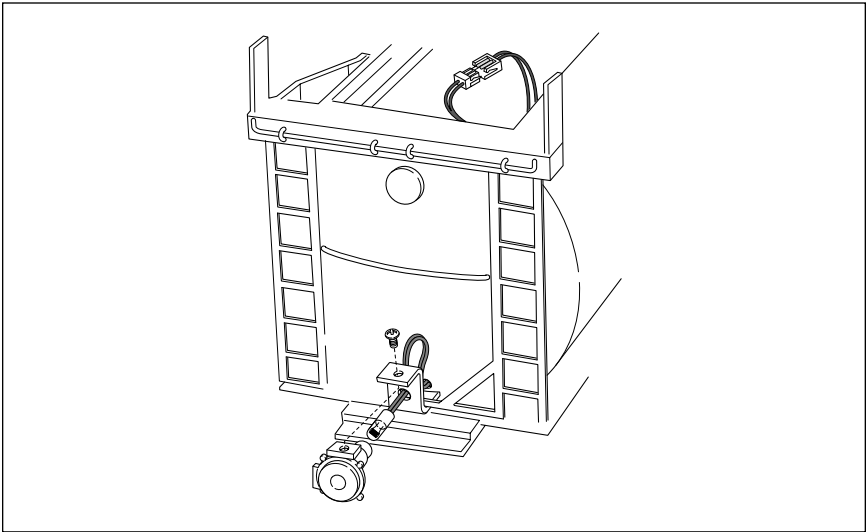

Figure 9. Tender back-up light replacement

Caring for your locomotive and tender antennas

The rear ladder, the fuel lines on the roof, and the vent housing detail serve as antennas that receive signals from the Command Base. Each antenna is insulated from the die-cast body of the locomotive to improve reception. Be sure that each stanchion and insulating sleeve remain intact and in place. Take care not to damage your locomotive's antennas.

The entire tender body is the antenna. It is important to keep the body insulated from the trucks. If you remove the trucks, be sure to reassemble the unit with the proper insulating washers. A shoulder washer is positioned below the frame, and a plastic insulating washer is positioned above the frame. The truck stud is held in place by a C-clip.

Limited Warranty/Lionel Service

This Lionel product, including all mechanical and electrical components, moving parts, motors and structural components, except for light bulbs, is warranted to the original consumer-purchaser, for **one year** against original defects in materials or workmanship when purchased through an authorized Lionel merchant.

This warranty does NOT cover normal wear and tear, light bulbs, defects appearing in the course of commercial use, or damage resulting from abuse or misuse of the product by the purchaser. Transfer of this product by the original consumer-purchaser to another person voids this warranty. Modification of this product voids this warranty.

Any warranted product which is defective in original materials or workmanship and is delivered by the original consumer-purchaser to Lionel L.L.C. or an authorized Lionel L.L.C. Service Center, together with proof of original purchase will, at the option of Lionel L.L.C., be repaired or replaced, without charge for parts or labor. In the event the defective product cannot be repaired, and a replacement is not available, a refund of the original purchase price will be granted. Any products on which warranty service is sought must be sent freight or postage prepaid, as transportation and shipping charges are not covered by the warranty.

In no event shall Lionel L.L.C. be liable for incidental or consequential damages.

Some states do not allow the exclusion or limitation of incidental or consequential damages, so the above exclusion may not apply to you.

This limited warranty gives you specific legal rights, and you may have other rights which vary from state to state.

Instructions for Obtaining Service

If service for this Lionel L.L.C. product is required, bring the item, along with your dated sales receipt and completed warranty information to the nearest Authorized Lionel Service Center.

Your nearest Lionel Service Center can be found by calling 1-800-4-Lionel, or by accessing our Website at www.lionel.com.

If you prefer to send your product back to Lionel L.L.C. for repair in Michigan, you must first call 586-949-4100 or FAX 586-949-5429, or write to Customer Service, P.O. Box 748, New Baltimore, MI 48047-0748, stating what the item is, when it was purchased and what seems to be the problem. You will be sent a return authorization letter and label to ensure your merchandise will be properly handled upon receipt.

Once you have received your return authorization and label, make sure that the item is packed to prevent damage during shipping and handling. We suggest that you use the product's original packaging. This shipment must be prepaid and we recommend that it be insured.

Please make sure you have followed all of the above instructions carefully before returning any merchandise for service. You may choose to have your product repaired by one of our Authorized Lionel Service Centers after its warranty has expired. A reasonable service fee will be charged.

Warranty Information

Please complete the information below and keep it, along with your dated sales receipt. You must present this and your dated sales receipt when requesting warranty service.

Name _____

Address _____

Place of Purchase _____

Date of Purchase _____

Product Number _____

Product Description _____

