



73-4672-251
8/12

Installing Shorter Diaphragms (optional)

The Lionel Centipede locomotives are shipped with a rubber diaphragm on the back end of each unit. When two units are coupled back-to-back, these diaphragms almost touch, giving the appearance of the prototype locomotives. For most users, the diaphragms will not affect the operation of the locomotives.

For users with certain S-curve track configurations, you may find that the diaphragms are pinched when the ends of the locomotives swing across the track. If you find that this occurs on your layout, you have the option of installing the extra diaphragms, which are shorter in length.

To replace the diaphragms, simply pull the four tabs out of the slots in the back of the locomotive. Use a small pointed tool (e.g., a straightened paper clip) to insert the tabs on the new diaphragm into the slots on the back of the locomotive.

Important! To maintain your warranty, do **not** remove the locomotives' body shells.

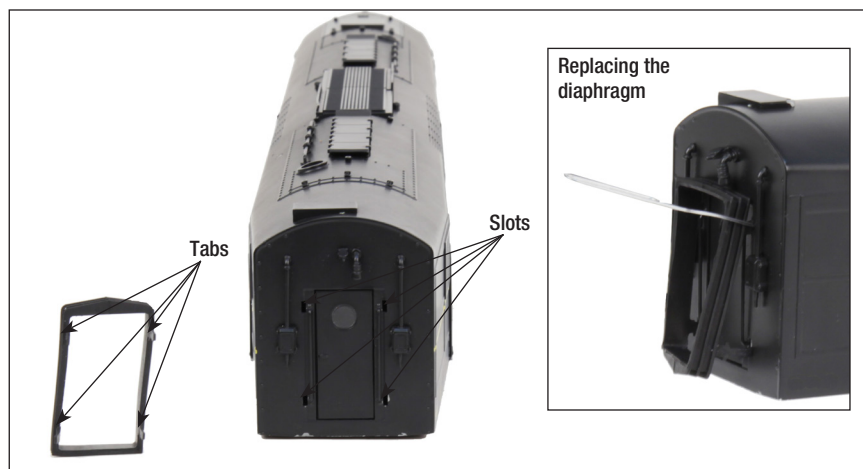

Figure 1. Replacing the diaphragms



73-4672-251
8/12

Installing Shorter Diaphragms (optional)

The Lionel Centipede locomotives are shipped with a rubber diaphragm on the back end of each unit. When two units are coupled back-to-back, these diaphragms almost touch, giving the appearance of the prototype locomotives. For most users, the diaphragms will not affect the operation of the locomotives.

For users with certain S-curve track configurations, you may find that the diaphragms are pinched when the ends of the locomotives swing across the track. If you find that this occurs on your layout, you have the option of installing the extra diaphragms, which are shorter in length.

To replace the diaphragms, simply pull the four tabs out of the slots in the back of the locomotive. Use a small pointed tool (e.g., a straightened paper clip) to insert the tabs on the new diaphragm into the slots on the back of the locomotive.

Important! To maintain your warranty, do **not** remove the locomotives' body shells.

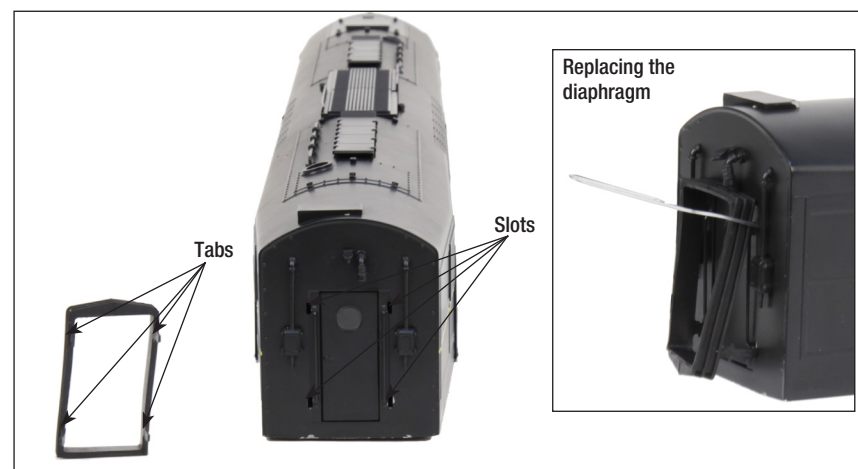

Figure 1. Replacing the diaphragms