

# LARGE SCALE 4-4-2 LOCOMOTIVES

8-5102 New York Central

8-5103 Santa Fe

8-5106 Chessie

8-5107 Great Northern

(Page 1 of 2)

18-5XXX-7  
Cab

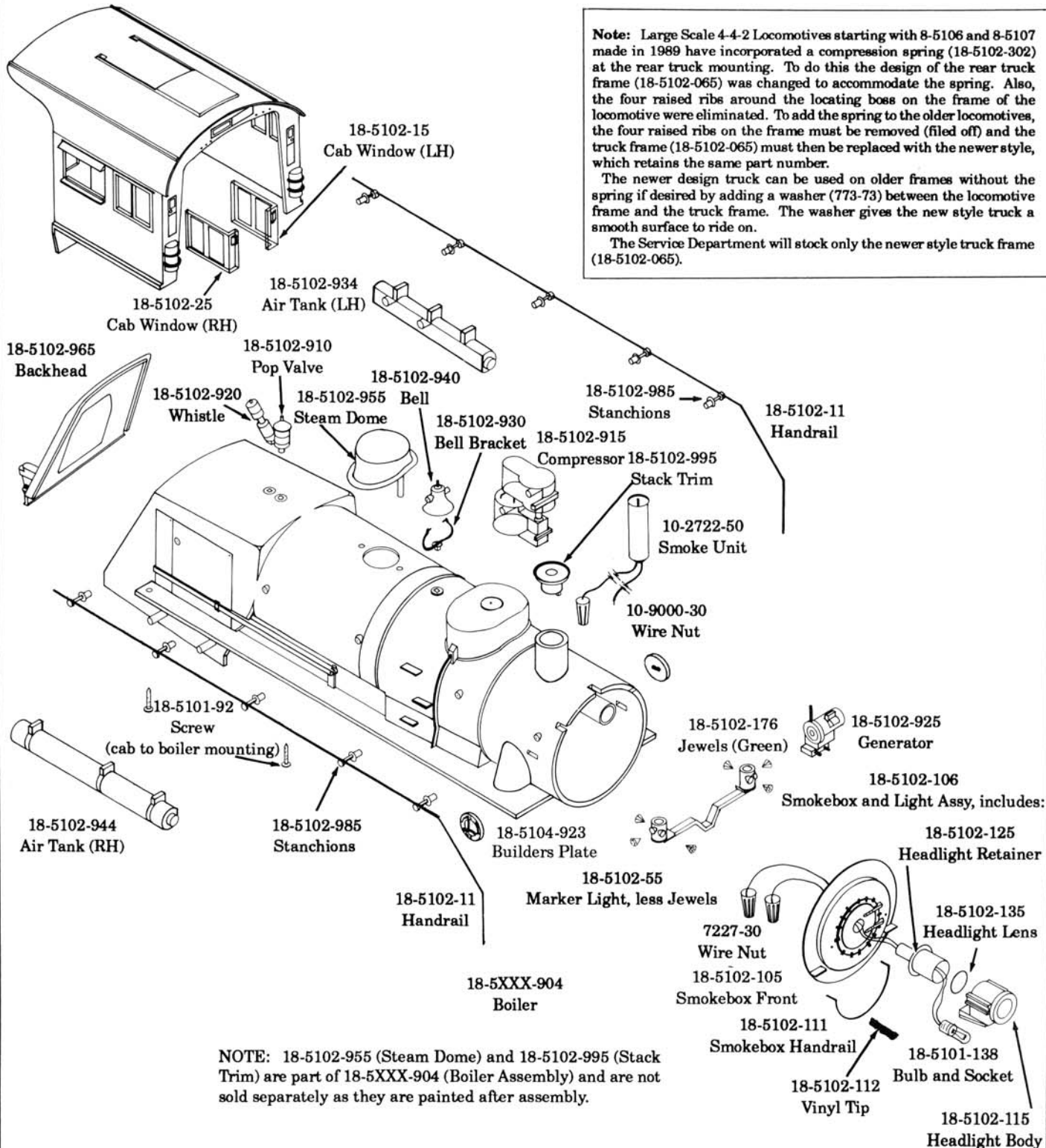

**Note:** Large Scale 4-4-2 Locomotives starting with 8-5106 and 8-5107 made in 1989 have incorporated a compression spring (18-5102-302) at the rear truck mounting. To do this the design of the rear truck frame (18-5102-065) was changed to accommodate the spring. Also, the four raised ribs around the locating boss on the frame of the locomotive were eliminated. To add the spring to the older locomotives, the four raised ribs on the frame must be removed (filed off) and the truck frame (18-5102-065) must then be replaced with the newer style, which retains the same part number.

The newer design truck can be used on older frames without the spring if desired by adding a washer (773-73) between the locomotive frame and the truck frame. The washer gives the new style truck a smooth surface to ride on.

The Service Department will stock only the newer style truck frame (18-5102-065).

**NOTE:** 18-5102-955 (Steam Dome) and 18-5102-995 (Stack Trim) are part of 18-5XXX-904 (Boiler Assembly) and are not sold separately as they are painted after assembly.

**LARGE SCALE 4-4-2 LOCOMOTIVES**

- 8-5102 New York Central
- 8-5103 Santa Fe
- 8-5106 Chessie
- 8-5107 Great Northern

(Page 2 of 2)

