

71-2888-250
3/04



Lionel
#154 Railroad
Crossing Flasher
Owner's Manual

Congratulations on your purchase of the Lionel #154 Railroad Crossing Flasher. Place the signal at any grade crossing on your Lionel railroad, and passing trains will automatically cause the red lights to flash.

Table of contents

Installing the 153C Contactor	3
Wiring your #154 Railroad Crossing Flasher to a power source	4
Adjusting the Contactor	5
Operating the #154 Railroad Crossing Flasher	5
Connecting your #154 Railroad Crossing Flasher to a 153IR Controller	5
Connecting your #154 Railroad Crossing Flasher with the FasTrack track system	6
Replacing your #154 Railroad Crossing Flasher's lamps	7
Limited Warranty/Lionel Service	8

The following Lionel marks may be used throughout this instruction manual and are protected under law. All rights reserved.

Lionel®, *TrainMaster®*, *Odyssey®*, *RailSounds®*, *CrewTalk™*, *TowerCom™*, *DynaChuff™*, *StationSounds™*, *Pullmor®*, *ElectroCoupler™*, *Magne-Traction®*, *CAB-1 Remote Controller®*, *PowerMaster®*, *Lionel ZW®*, *ZW®*, *PowerHouse®*, *TMCC®*, *Lionelville™*, *Lockon®*

The name FasTrack® is used with permission from Pitsco, Inc.

Installing the 153C Contactor

The 153C Contactor is activated by the weight of a passing train. Place the Contactor under the track, as shown in Figure 1.

One of the track ties should rest firmly upon the top of the pressure plate. If your track is fastened to a board, loosen several sections on either side of the Contactor so that the track is able to bend under the weight of the train.

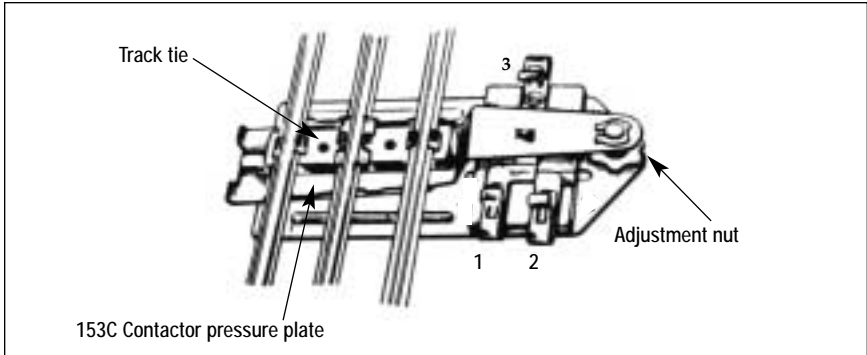

Figure 1. 153C Contactor

Wiring your #154 Railroad Crossing Flasher to a power source

Your #154 Railroad Crossing Flasher operates best at 12-18 volts (AC). Have an adult strip 1/4" of insulation from the ends of the three wires included with the #154 Railroad Crossing Flasher, if they have not already been stripped.

Caution! Only an adult should perform this task. Always use care when stripping wires.

Attach one wire to each terminal post on the base of the accessory. Connect the ends of the wires to the #153C Contactor and transformer as shown in Figure 2 below.

To connect a wire to the Contactor's spring clips, press down the upper half of the spring clip terminal until the lower part projects through the slot. Insert the bare wire end into the loop, then release the upper part of the clip. Spring tension will hold the wire tight.

Note! This accessory will also operate using an insulated track section (available separately).

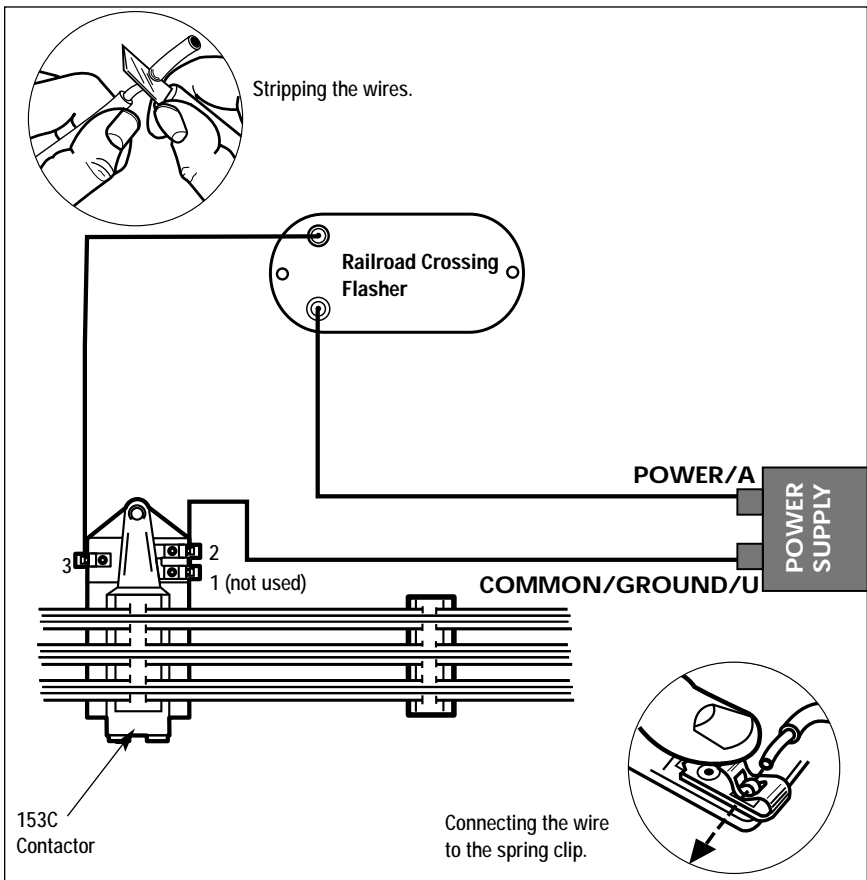

Figure 2. Accessory connection

Adjusting the Contactor

After all the connections are made and your layout is powered up, the Contactor must be adjusted so that the train will properly trigger the accessory.

1. Stop the train several sections away from the Contactor so that it does not press on the Contactor plate.
2. Turn the adjustment nut either up or down until the signal is activated. Refer to Figure 1 on page 3 for the location of the adjustment nut.
3. Back up the adjustment nut just enough to turn off the signal.

Operating the #154 Railroad Crossing Flasher

When properly adjusted, the 153C Contactor will respond to light pressure on the track, causing the lights to flash as long as any part of the train is triggering the Contactor. After the train has cleared the Contactor, the signal will turn off.

Connecting your #154 Railroad Crossing Flasher to a 153IR Controller

The 153IR Controller (available separately, 6-14111) is an alternative to the 153C Contactor. While the 153C Contactor relies on the weight of the train to cause the contact points to change, the 153IR Controller is triggered by an Infrared motion sensor. The 153IR Controller also allows you to set the length of time that the accessory remains on. Consult the 153IR Controller owner's manual for more information and refer to Figure 3 below.

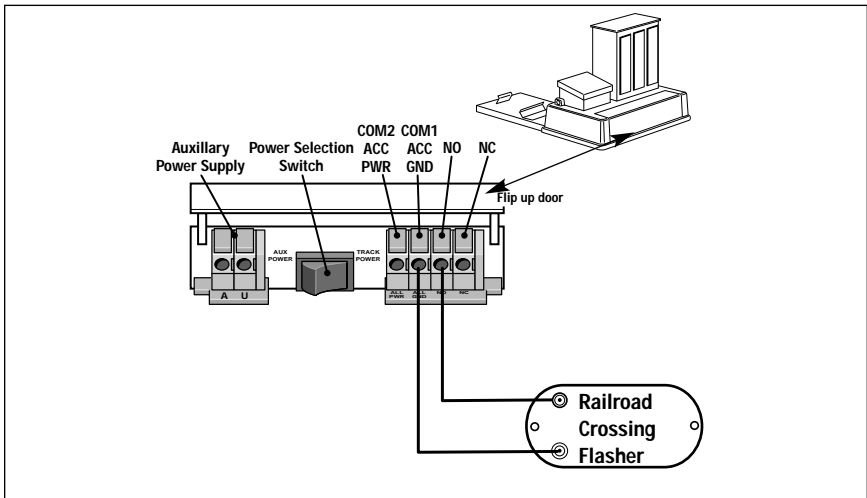

Figure 3. 153IR connections

Connecting your #154 Railroad Crossing Flasher with the FasTrack Track System

To operate this accessory with the FasTrack track system, you will need the Accessory Activator Pack (available separately, 6-12029). To make the proper connections, the ends of the wires should be stripped back 1/8" to 1/4".

Caution! Only an adult should perform this task. Use a pair of wire strippers to strip the wires. Always use care when stripping wires.

Simply connect the two wires from the Insulated Track section directly to your accessory's power terminals. Refer to Figure 4. The accessory receives power from the track and operates at track voltage. You must be sure that the track is given enough power to operate the trains and your accessory. The accessory will operate only when the track is powered up and the train is between the breaks in the rail.

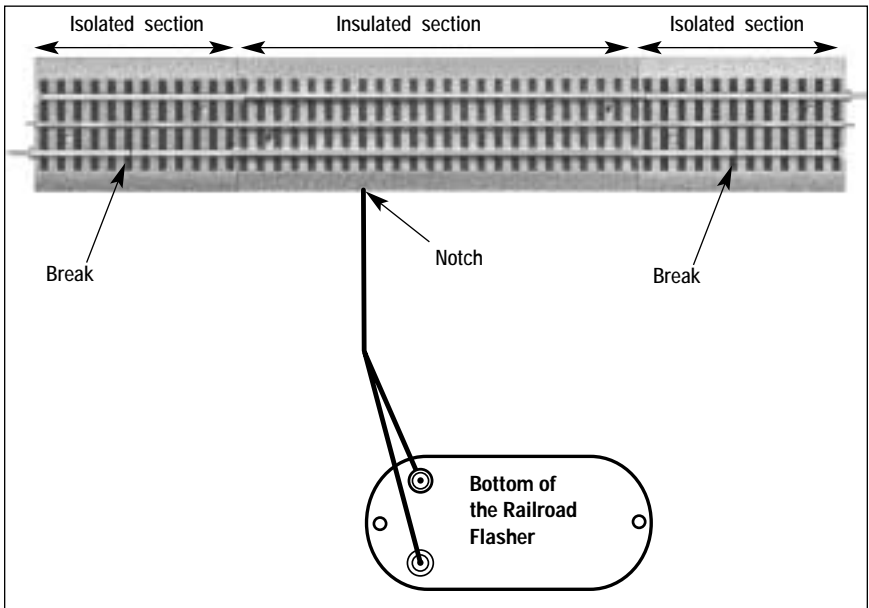

Figure 4. Track power connections

Replacing your #154 Railroad Crossing Flasher's lamps

To replace the lamps on your Railroad Crossing Flasher, gently pull the lamp and socket assembly straight out. Do not twist the bulb. Replace the lamp with Lionel part no. 600-8352-900, available from your authorized Lionel Service Center or Lionel Service in Chesterfield, MI.

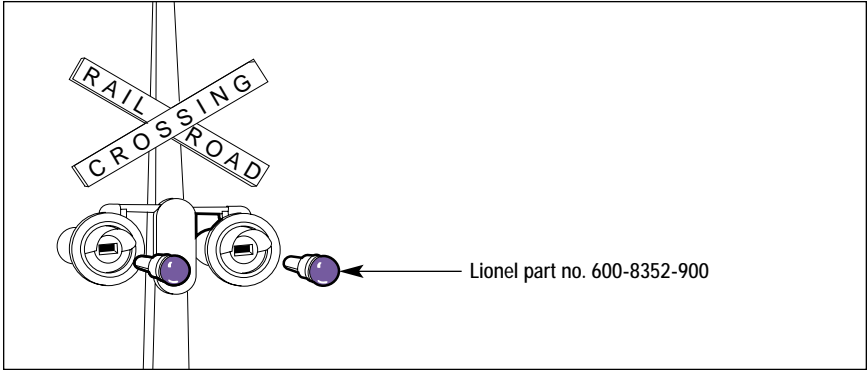

Figure 5. Lamp replacement

Limited Warranty/Lionel Service

This Lionel product, including all mechanical and electrical components, moving parts, motors and structural components, except for light bulbs, is warranted to the original consumer-purchaser, for **one year** against original defects in materials or workmanship when purchased through an authorized Lionel merchant.

This warranty does NOT cover normal wear and tear, light bulbs, defects appearing in the course of commercial use, or damage resulting from abuse or misuse of the product by the purchaser. Transfer of this product by the original consumer-purchaser to another person voids this warranty. Modification of this product voids this warranty.

Any warranted product which is defective in original materials or workmanship and is delivered by the original consumer-purchaser to Lionel L.L.C. or an authorized Lionel L.L.C. Service Center, together with proof of original purchase will, at the option of Lionel L.L.C., be repaired or replaced, without charge for parts or labor. In the event the defective product cannot be repaired, and a replacement is not available, a refund of the original purchase price will be granted. Any products on which warranty service is sought must be sent freight or postage prepaid, as transportation and shipping charges are not covered by the warranty.

In no event shall Lionel L.L.C. be liable for incidental or consequential damages.

Some states do not allow the exclusion or limitation of incidental or consequential damages, so the above exclusion may not apply to you.

This limited warranty gives you specific legal rights, and you may have other rights which vary from state to state.

Instructions for Obtaining Service

If service for this Lionel L.L.C. product is required, bring the item, along with your dated sales receipt and completed warranty information to the nearest Authorized Lionel Service Center. Your nearest Lionel Service Center can be found by calling 1-800-4-Lionel, or by accessing our Website at www.lionel.com.

If you prefer to send your product back to Lionel L.L.C. for repair in Michigan, you must first call 586-949-4100 or FAX 586-949-5429, or write to Customer Service, P.O. Box 748, New Baltimore, MI 48047-0748, stating what the item is, when it was purchased and what seems to be the problem. You will be sent a return authorization letter and label to ensure your merchandise will be properly handled upon receipt.

Once you have received your return authorization and label, make sure that the item is packed to prevent damage during shipping and handling. We suggest that you use the product's original packaging. This shipment must be prepaid and we recommend that it be insured.

Please make sure you have followed all of the above instructions carefully before returning any merchandise for service. You may choose to have your product repaired by one of our Authorized Lionel Service Centers after its warranty has expired. A reasonable service fee will be charged.

Warranty Information

Please complete the information below and keep it, along with your dated sales receipt. You must present this and your dated sales receipt when requesting warranty service.

Name _____

Address _____

Place of Purchase _____

Date of Purchase _____

Product Number _____

Product Description _____



©2004 LIONEL L.L.C., CHESTERFIELD, MI 48051-2493
UNITED STATES OF AMERICA
PRINTED IN CHINA