



71-1117-250  
2/08



***Lionel  
E6 4-4-2 Atlantic  
Locomotive and Tender  
Owner's Manual***

Featuring

**LEGACY**  
R·A·I·L·S·O·U·N·D·S



# ***Congratulations!***

**C**ongratulations on your purchase of the Lionel GS-4 Northern locomotive and tender! On the outside, this locomotive features numerous prototypical details and expert decoration in your favorite livery. Inside the body, this locomotive is equipped with some of the most advanced sounds and controls in model railroading. This powerful locomotive is ready for duty on your layout.

## **Features of this locomotive**

---

- **LEGACY Control System equipped—able to run with the new LEGACY Control System, in the TrainMaster Command Control environment, or in the conventional environment with only a standard transformer**
- **Odyssey II Speed Control with ON/OFF switch**
- **Five official railroad speeds with CrewTalk dialog**
- **Refined Conventional Transformer Control Mode with lower starting speeds, improved smoke output**
- **Powerful maintenance-free motor with momentum flywheel**
- **Puffing synchronized fan-driven smoke unit with adjustable smoke output**
- **Illuminated headlight on locomotive**
- **Illuminated classification lights on locomotive**
- **Wireless Tether connection between locomotive and tender**
- **LEGACY RailSounds sound system with real-time quilling whistle**
- **FatBoy speaker for the ultimate in sound reproduction**
- **ElectroCoupler on rear of tender**
- **Illuminated marker lights on rear of tender**
- **Minimum curve: 0-31**

The following Lionel marks may be used throughout this instruction manual and are protected under law. All rights reserved.

*Lionel®, TrainMaster®, Odyssey®, RailSounds®, CrewTalk™, TowerCom™, DynaChuff™, StationSounds™, Pullmor®, ElectroCoupler™, Magne-Traction®, CAB-1® Remote Controller, PowerMaster®, Lionel ZW®, ZW®, PowerHouse®, TMCC®, Lionelville™, Lockon®, Wireless Tether™, LionMaster®, FatBoy™, American Flyer®, TrainSounds™, PowerMax™, LEGACY™, PowerMax™ Plus*

*The name FasTrack® is used with permission from Pitsco, Inc.*

# Table of contents

---

## **Quick Start**

LEGACY Control operations	4
TrainMaster Command Control operations	4
Transformer operations	4

## **LEGACY Control System operations**

Get ready to run	5
Start 'Er Up	5
The LEGACY CAB-2 Controller	6
The Velocity Throttle	7
The Multi-Controller	7-8
The Train Brake Slider	8
The Warning Sound Controller	9
The Speed Bar	10

## **Locomotive switch function overview**

Switch overview	11
-----------------	----

## **TrainMaster Command Control operations**

TrainMaster Command Control operations	12
Operating your locomotive in the Command Control environment	12
CAB-1 Remote Controller commands	13
CAB-1 Remote Controller numeric keypad commands	14
Tuning your locomotive's chuff intensity and performance	15-16
Assigning your locomotive a new ID#	17
Reprogramming your locomotive to restore features	18

## **Conventional transformer operations**

Operating your locomotive in the conventional environment	19-20
Locking your locomotive into a single direction	21
Uncoupling in the conventional environment	22

## **Odyssey II Speed Control system operations**

Odyssey II Speed Control system operations	23
Odyssey II Speed Control system LEGACY Control operation	23
Odyssey II Speed Control system TrainMaster Command Control operation	23
Odyssey II Speed Control system conventional transformer operation	23

## **LEGACY RailSounds Sound System operations**

LEGACY RailSounds sound system operations	24
Installing the battery	25-26
Using the LEGACY RailSounds sound system in the TrainMaster Command Control environment	27
Using the LEGACY RailSounds sound system in the conventional environment	28
Installing a Lionel Sound Activation Button for conventional operation	29
Activating the CrewTalk dialog and TowerCom announcements in the conventional environment	30

## **Maintaining and servicing your locomotive**

Adding fluid to your locomotive's smoke generator	31
Adjusting the smoke output	31
Lubricating your locomotive	32
Maintaining your locomotive's handrail antenna	33
Servicing your locomotive's lamps	33
Tire-Traction	34
Notes	35
Limited Warranty/Lionel Service	36

## Quick Start

**Note!** Power your locomotive with an alternating-current (AC) transformer only. Powering your locomotive with a direct-current (DC) transformer, or in excess of 19 volts AC, may result in damage to sensitive electronic components.

### LEGACY Control operations

---

**F**or the finest operating experience, your locomotive is fully compatible with the new LEGACY Control System.

To operate in LEGACY mode, you need a LEGACY Command Base and LEGACY CAB-2 Remote Controller. Both products are offered together in the LEGACY Command Set, 6-14295.

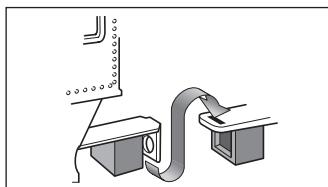

Figure 1. Drawbar connection

1. **Turn off track power and plug in the LEGACY Base.**
2. **Place your locomotive on Lionel or Lionel-compatible 0-31 or larger track and connect the drawbar between the locomotive and tender as illustrated in Figure 1.**
3. **Increase track power voltage to full power (no more than 19 volts AC).**
4. **Press ENG and 1 to address your locomotive with your LEGACY CAB-2 Remote Controller.**
5. **Throttle up and move 'em out.**

### TrainMaster Command Control operations

---

**T**o operate your locomotive in the Command Control environment, you need a Command Base (available separately, 6-12911) and a CAB-1 Remote Controller (available separately, 6-12868).

1. **Turn off track power and plug-in the Command Base.**
2. **Place your locomotive on Lionel or Lionel-compatible 0-31 or larger track and connect the drawbar between the locomotive and tender as illustrated in Figure 1.**
3. **Increase track voltage to full power (no more than 19 volts AC).**
4. **Press ENG and 1 to address your locomotive with your CAB-1 Remote Controller.**
5. **Throttle up and move 'em out.**

### Transformer operations

---

1. **Place your locomotive on Lionel or Lionel-compatible 0-31 or larger track and connect the drawbar between the locomotive and tender as illustrated in Figure 1.**
2. **Power your locomotive at 12-18 volts with your alternating current (AC) transformer.**
3. **Wait three to eight seconds until the locomotive's headlight illuminates and the LEGACY RailSounds sound system starts up.**
4. **Move 'em out! Press the DIRECTION button on your controller, then throttle up.**

# LEGACY Control System operations

**Note!** This section is a brief overview of the LEGACY Control System. For a more in depth explanation of the LEGACY Control System features, please see your LEGACY Control System Operations Manual.

## GET READY TO RUN

---

**G**et your engine running now by following the instructions in this guide. We'll power up the track, "address the engine" so it can be controlled by your CAB-2 remote and learn to use the Velocity Throttle, Whistle, Bell, Brake and Direction commands.

### Power Up The Track

Refer to PowerMaster, TPC, or ZW manual for the correct method to power up. With your locomotive on the track and ready to roll, power-up your track to a constant 18 volts. If a circuit breaker trips when you turn on the Lionel power supply, check the wheels of your locomotive to make sure they are all securely on the track. Check to make sure the track is free of all metals that may cause a short circuit.

### Address Your Engine

First, you must address the engine. This "tells" your CAB-2 which locomotive you want to control. This is important when you have more than one engine on your layout.

To address an engine:

1. Press ENG
2. Press 1
3. Press Start Up

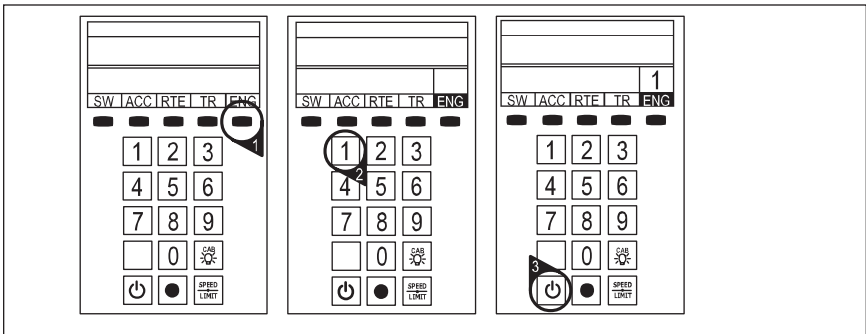

See reference numbers 1, 2, and 3

## Start 'Er Up

---

Now it is time to start up your engine's sound system.

To start the engine's Railsounds system, press Start on the touch-screen or any action key (Whistle, Bell, Velocity Throttle, etc.).

Your engine sound system will start up and the Touch-screen Control Panel will appear.

# LEGACY Control System operations

## The LEGACY CAB-2 Remote Controller

### Main Display

Displays real-time information about your railroad system. Displays real-time feedback of operation.

### Scroll Button

Navigates through the entire list of Engines, Trains, Switches, etc.

### Select Button

Performs addressing by 3-4 digit road number.

### Touch Screen Key Pad

A group of touch sensitive keys with icons for each function. These keys serve many purposes and their icons change accordingly.

### Train Brake Slider

This slider is used to increase or decrease the amount of Train Brake effecting the engine or train.

### Train Link Button

For future use.

### AUX-1/Thru Button

Press to view the Control Panel while operating. Controls switch direction.

### AUX-2/Out Button

Controls switch direction.

### Emergency Halt Button

Stops everything on layout, also stops recording playback.

### Record Button

Used to record and playback events.

### Velocity Throttle

Throttle control over engines, also used to navigate thru info/options.

### Set Button

Used to set Engine address and for programming.

### Info Button

Used to enter/view the info/options of selected components.

### CTC Button

Turns the Remote Control ON and OFF. Used to enter the Remote and Base options. Pressing CTC while in a menu will always bring you back to main screen.

### Soft Keys

These keys directly correlate to the 5 selection boxes located at the bottom of the main screen. These are also used in the info/options menus to select options.

### Warning Sound Controller

Warning Bell and Variable Whistle/Horn control. Pull down to sound Whistle/Horn. Push up and release to trigger Warning Bell.

### Official R.R. Speed Control Bar

Toggles the touchscreen display of R.R. preset speeds and control panel.

### Multi Controller

Boost, Brake, and Direction control. Rock forward for Boost, rock backward for engine brake, and press down for direction change. Click-hold-and rock for absolute direction select.

### Front & Rear Coupler Buttons

Fire couplers.

### Feedback Buttons

Toggle ON/OFF the vibration feedback feature in the CAB-2 Remote.

### Low, Medium, High Momentum Buttons

Used to select the desired momentum of your addressed engine/train/accessory.

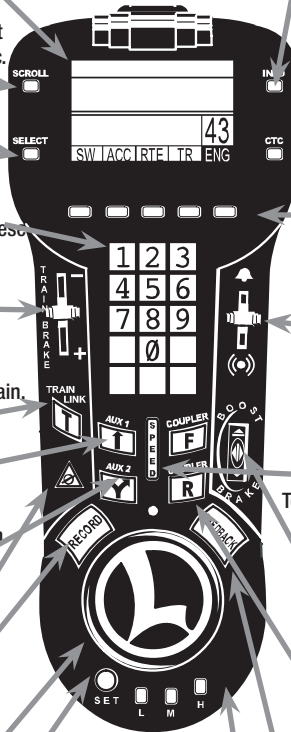

# LEGACY Control System operations

## THE VELOCITY THROTTLE

---

**T**he Velocity Throttle (that big red rotary knob in the middle of your Lionel remote) is used to start your engine moving, slow it down or speed it up. Use it simply by turning it clockwise (speed up) or counter-clockwise (slow down).

4. Turn the Velocity Throttle clockwise a small amount. Your engine will begin to move.
5. Experiment with the engine's response to the Velocity Throttle. Turn the Velocity Throttle clock-wise and counter-clock-wise.
6. Slow and stop your engine by turning the Velocity Throttle counter-clockwise.

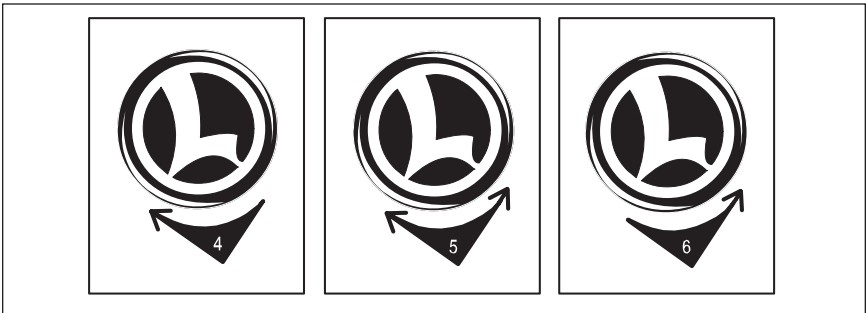

See reference numbers 4, 5, and 6

## THE MULTI-CONTROLLER

---

### *Direction*

The direction of your engine toggles between forward and reverse at the touch of the Multi-Controller.

7. Press the Multi-Controller once. Your engine's lights will change directions.
8. Turn the Velocity Throttle clockwise a small amount. Your Engine will reverse directions and travel in the opposite direction.

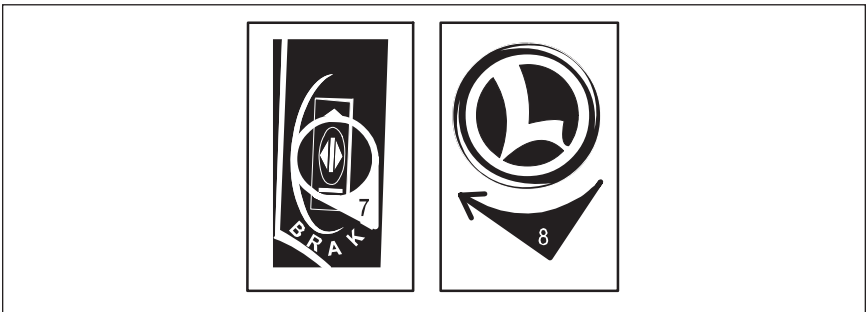

See reference numbers 7, and 8

# LEGACY Control System operations

## THE MULTI-CONTROLLER (continued)

### Boost & Brake

Boost and brake give you another way to control the speed of your train. Boost gives your loco a temporary increase in tractive power, and returns to the previous speed when you release the control, while the brake command slows you down quicker than the Velocity Throttle alone and holds your speed at the adjusted level.

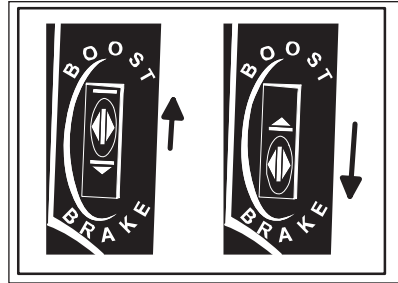

9. Experiment with Boost and Brake. Notice how your engine responds to the Multi-Controller. See reference number 9

## THE TRAIN BRAKE SLIDER

**A** Train Brake is used to slow down and limit the top speed of your train by adding a load. The more the Train Brake is applied by pulling the Train Brake Slider down, the more laboring is heard from the engine. Eventually Train Brake application will slow down the train and it is even possible to stop a train by pulling the Train Brake Slider all the way down. A tremendous amount of laboring can be heard whenever you apply the Train Brake in a large amount.

10. Experiment with the Train Brake. Try a small amount of the Train Brake when your engine is moving down the rails at a medium speed. Notice the effect the Train Brake has on sound and speed. Try adding more Train brake and notice that the Train Brake can limit the top speed available to your engine.

Try adding even more Train Brake and notice that the Engine sounds like it is working harder and harder as the Train Brake is applied more.

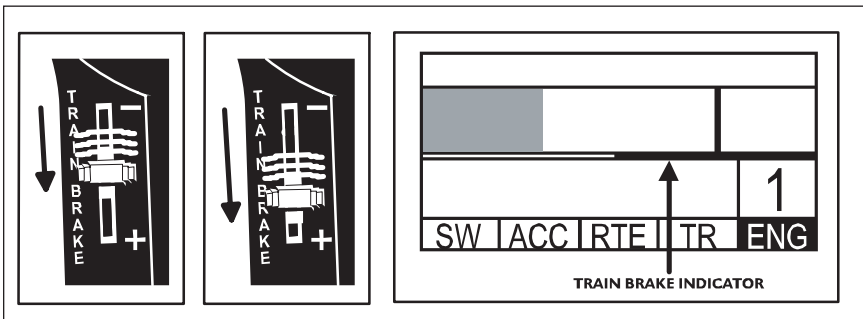

See reference number 10



# ***LEGACY Control System operations***

## **THE WARNING SOUND CONTROLLER**

---

**W**arning sounds are an important part of Lionel Railroading. Your Lionel Legacy Control System equipped engines have a real-time variable "quilling" whistle and horn, while Lionel TMCC engines do not have this feature.

11. Blow the Horn/Whistle by pulling down on the Warning Sound Controller.
12. Try pulling down the Warning Sound Controller various amounts and listen. Notice the difference in intensity of the Whistle or Horn.
13. Push the Warning Sound Controller up once and quickly release. Notice that the bell rings once.
14. Push the Warning Sound Controller up and hold it for 1.5 seconds. Notice that the Bell is sounding continuously.
15. Push the Warning Sound Controller up once. Notice that the continuous Bell stops.
16. Experiment with ringing the Bell in your own rhythm or continuously, depending on how you push the Warning Sound Controller

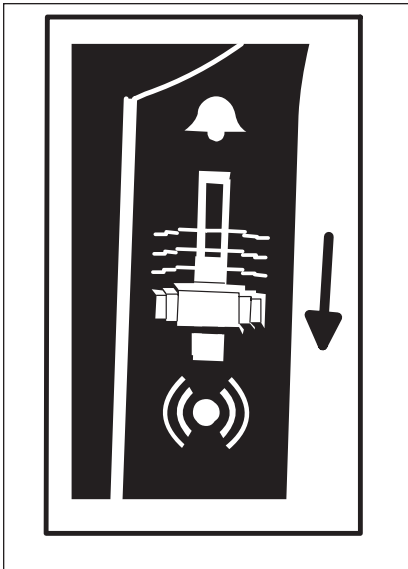

See reference numbers 11, and 12

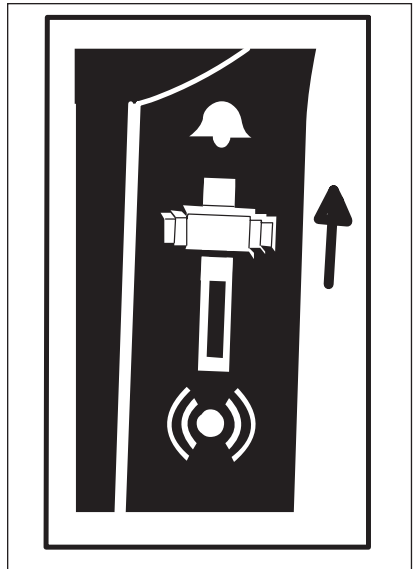

See reference numbers 13, 14, 15, and 16

# LEGACY Control System operations

## THE SPEED BAR

### Selection of Official Rail Road Speeds

The Speed Bar is used to select a new touch-screen Icon Control set. This set of touch-screen keys is used to select official Railroad Speeds. Two additional controls, "High Ball," (Top Speed) and "Brake to Roll," (speed step one) are possible with this Touch-Screen set of controls. Pressing AUX-1 returns you to the standard control panel.

17. Press, hold and release the RR Speed icons one by one. Experiment.
18. The speed of the engine changes with each press and release of a different RR Speed key.
19. TowerCom dialog occurs each time you press and hold a RR speed key.
20. The Engineer dialog responds and the speed of the engine changes as soon as you release the RR speed key.
21. If you touch a RR speed key and release it quickly, a speed change is enabled with no dialog scene.
22. You can also use the Velocity Throttle and other action controls in this mode and continue to use Official RR speeds at the same time.
23. Repeat step 17.
24. Press AUX-1 to leave the RR speed mode and return to the standard mode and return to the standard control panel.
25. Press the speed bar to toggle between the Official RR Speed Control Panel and the Standard Control Panel.

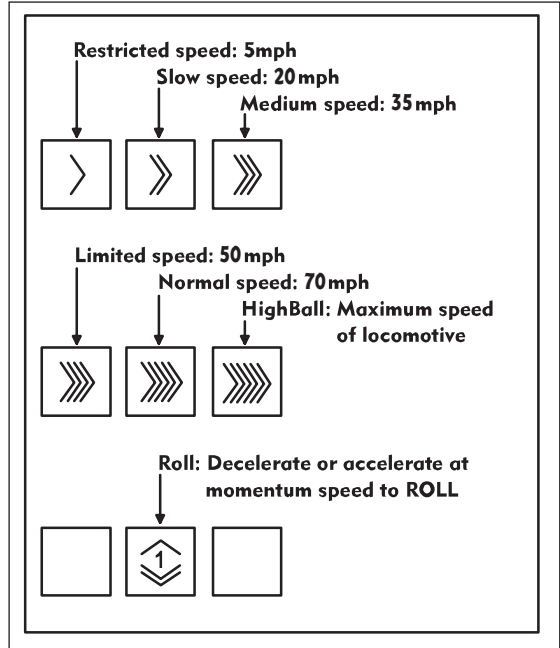

See reference numbers 17, 18, 19, 20, 21, 22, 23, 24 and 25

At this point you know the basics of how to operate. There is a lot of fun waiting as you experience the interaction of the controls and the touch-screen.

Be sure to read the entire Lionel Legacy Control System Manual to get the most from your Lionel products.

# Locomotive switch function overview

## Switch overview

---

### Command Reverse Unit Switch

Used to assign an ID# and reprogram the locomotive in LEGACY and Command operation when the switch is in the “PROG” position. Also used to “lock” your locomotive in a single direction, or neutral, in conventional operation when the switch is placed in the “PROG” position. See pages 17, 18, and 21.

### Smoke Unit Switch

Used to turn the smoke unit function “on” and “off”. See page 31.

### Odyssey II Speed Control System Switch

Used to turn the Odyssey II Speed Control System “on” and “off”. See pages 20, and 23.

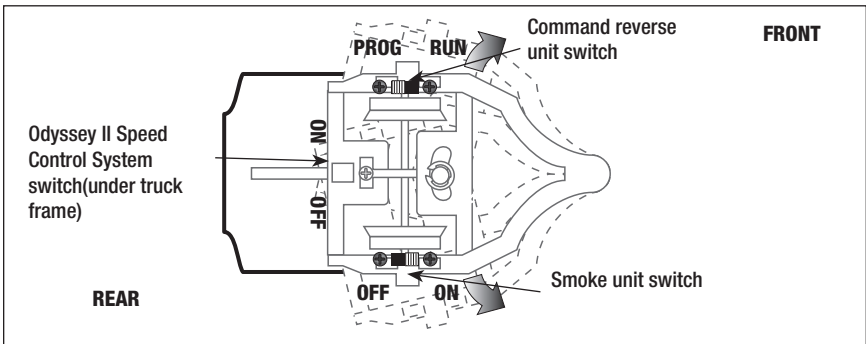

Figure 3. Switch locations

# ***TrainMaster Command Control operations***

## **TrainMaster Command Control operations**

---

In addition to your transformer, to operate your locomotive in the Command Control environment, you need a Command Base (available separately, 6-12911) and a CAB-1 Remote Controller (available separately, 6-12868).

Your commands are sent by the CAB-1 Remote Controller to the Command Base, which then translates the command into digital code. That code is sent through the outside rails to your locomotive, which will not respond until it recognizes its unique ID#. TrainMaster Command Control gives you the power to operate multiple Command-equipped locomotives on the same track at the same time.

Keep in mind that track power is like gasoline in the tank of a car—it gives you the power to go places, but it doesn't tell you where to go or how fast to get there.

## **Operating your locomotive in the Command Control environment**

---

- 1. Turn off track power and plug in the Command Base.** Be sure that the Command Base is connected to the outside rail or to the Common/Ground/U terminal on your track power supply.
- 2. Place your locomotive on Lionel or Lionel compatible 0-31 or larger track.**
- 3. Increase track voltage to full power (no more than 19 volts AC).** On PowerMasters, slide the CMD/CONV switch to CMD. Program Track Power Controllers to Command Control operation.

**Caution!** Power your locomotive with an alternating-current (AC) transformer only. Powering your locomotive with a direct-current (DC) transformer, or in excess of 19 volts AC, may result in damage to sensitive electronic components.

- 4. Press ENG and enter the ID# to address your locomotive with your CAB-1 Remote Controller.** All Lionel locomotives come factory-programmed as ID# 1. To change the ID#, see page 17.
- 5. Throttle up and move 'em out!** Your locomotive will respond to every command from your CAB-1 Remote Controller.

# TrainMaster Command Control operations

## CAB-1 Remote Controller commands

The CAB-1 Remote Controller commands are detailed below. *The corresponding RailSounds sound system effects are in bold italic type.*



**Coupler release sound.**



Releases the ElectroCoupler on the rear of the tender. **Coupler release sound.**



Activates the numeric keypad. **Short steam release sound.**



Toggles the headlight on and off.



Accelerates the locomotive with a clockwise rotation. Decelerates the locomotive with a counter-clockwise rotation. **Speed-dependent chuffing sounds. DynaChuff dynamic chuffing effect.**



Activates the locomotive's whistle. Release the button to discontinue the sound. **Whistle, steam whistle sound.**



Toggles the bell sound on and off. **Bell sound.**



Changes the locomotive's direction. The locomotive decelerates to a stop and continues in the opposite direction when you increase the throttle. **Air release sound.**



Increases the locomotive's speed while the button is pressed. Release the button to return to the initial speed. **Labored chuff.**



Decreases the locomotive's speed while the button is pressed. **Squealing brake sounds.**



Shuts down all PowerMasters on your railroad. Stops all TrainMaster Command Control-equipped locomotives in operation. Use **HALT** only in emergency situations.



L = 32 speed steps  
M = 100 speed steps  
H = 100 speed steps with momentum.

# ***TrainMaster Command Control operations***

## **CAB-1 Remote Controller numeric keypad commands**

---

**W**hen you press the **AUX1** button on your CAB-1 Remote Controller, you turn the numeric keypad into ten command buttons. After you press the **AUX1** button, you will be able to press any numbered button until you address a different product. ***The corresponding RailSounds sound system effects are in bold italic type.***

- 0** Stops and resets the locomotive. Resets the locomotive's direction to forward. Resets the RailSounds sound system to Automatic Chuff Mode. ***Air release sound.***
- 1** Raises the volume of the LEGACY RailSounds sound system background sounds, such as chuff sounds and let-off sounds. The whistle, bell and dialog are unaffected. The default is full volume. The volume setting is retained when track power is turned off. ***Sound volume increases.***
- 2** Engineer begins radio dialog, dispatcher replies (see pages 27 and 28). ***CrewTalk communication.***
- 3** Starts the RailSounds sound system if the locomotive was previously shutdown. Triggers the water pump sounds. ***Steam effects.***
- 4** Lowers the volume of the LEGACY RailSounds sound system background sounds, such as chuff sounds and let-off sounds. The horn, bell, and dialog are unaffected. The volume setting is retained when track power is turned off. ***Sound volume decreases.***
- 5** Activates the LEGACY RailSounds sound system shutdown sequence when stopped. Activates the emergency stop feature while in motion. Note that in the shutdown sequence, the smoke unit does not turn off if it was already on. To turn off the smoke unit, press **AUX1, 8** or use the smoke unit Smoke ON/OFF switch.
- 6** Activates Manual Chuff Mode (see page 15) to set the chuff intensity manually. Triggers the ***"Blow Down" sound.***
- 7** Dispatcher begins radio dialog, engineer replies (see pages 27 and 28). ***TowerCom announcement.***
- 8** Turns off the smoke unit. ***Let-off sound.***
- 9** Turns on the smoke unit if the smoke unit switch is in the ON position. Be sure to add smoke fluid before turning on the smoke unit to prevent damage to your locomotive. ***Let-off sound.***

**Note!** **AUX1, 8** and **9** function only if the locomotive's smoke unit switch is in the ON position.

**Note!** See the Lionel web site for more information.

# ***TrainMaster Command Control operations***

## **Tuning your locomotive's chuff intensity and performance**

---

**T**rainMaster Command Control allows you to fine-tune the performance of your locomotive. Use your CAB-1 Remote Controller to make these adjustments.

**Note!** These settings will be lost if you assign a new ID#.

### ***Chuff intensity***

Your locomotive is equipped with DynaChuff, the realistic steam chuffing sounds produced by the RailSounds sound system. Your locomotive's chuff rate is always synchronized with the drive wheels and the speed of the locomotive. The chuff intensity is also capable of varying automatically with the speed of the locomotive in automatic chuff mode. You may also choose to set a constant, or fixed, chuff intensity in manual chuff mode. There are 15 chuff intensity levels.

### ***Automatic chuff mode***

When you first throttle up, the intensity of the chuff sounds will vary with adjustments to the throttle. When you stop the locomotive for two seconds or more, the sounds will return to their initial intensity.

The initial chuff intensity simulates the sounds of the locomotive pulling a heavy string of cars. Keep in mind that you may choose to reduce the initial intensity of the chuff sounds to simulate a lighter load on the locomotive by pressing the **BRAKE** button while your locomotive is at rest. This will reduce the initial chuff intensity to the lowest level.

### ***Manual chuff mode***

Manual chuff mode allows you to set a constant chuff intensity for your locomotive. The intensity of the chuff sounds does not vary with the throttle settings or the speed of the locomotive.

To set a constant chuff intensity, get your locomotive moving, then press **AUX1, 3** or **AUX1, 6** to enter manual chuff mode. The locomotive will be locked at the current chuff intensity. To adjust this chuff intensity, press **3** to increase the intensity of the chuffing or press **6** to decrease the intensity of the chuffing. The locomotive will save this intensity level.

If you press **AUX1, 3** while the locomotive is at rest, the chuffing will be set to the maximum intensity. If you press **AUX1, 6** while the locomotive is at rest, the chuffing will be set to the lowest intensity. Once the locomotive is in motion, you may use the **3** and **6** buttons to increase and decrease the intensity of the chuff sounds.

When you press **AUX1, 3** or **AUX1, 6**, you have a ten-second "window" to adjust the chuff intensity. During this time, the water injector (**3**) and the air horn (**6**) sound will not be triggered by the **3** and **6** buttons. After ten seconds, the **3** and **6** buttons will be reassigned to activate the sounds. To adjust the chuff intensity after the ten seconds have elapsed, simply press **AUX1, 3** or **AUX1, 6** again.

To exit manual chuff mode, turn off track power and allow the locomotive to reset, enter the shutdown sequence (**AUX1, 5**) or reset the locomotive (**AUX1, 0**).

**Note!** The water injector sounds (**3**) and Blow Down sound (**6**) are inactive during the first ten seconds of entering manual chuff mode. These sounds are restored after the ten seconds have elapsed. If you wish to adjust the chuff intensity again, press **AUX1, 3** and **AUX1, 6** to open another ten-second programming "window".

# ***TrainMaster Command Control operations***

## **Tuning your locomotive's chuff intensity and performance (continued)**

### ***Volume***

The RailSounds sound system gives you greater control over the volume of your locomotive's sounds. Pressing **AUX1, 1** raises the volume of the chuffing and boiler sounds, and **AUX1, 4** lowers the volume. There are nine volume levels.

**Note!** The volume level you set will be saved and restored upon power-up. Press **AUX1, 1** and **4** to adjust the volume.

The whistle, bell, CrewTalk dialog, and TowerCom announcement sounds play at full volume, regardless of the settings entered with the CAB-1 Remote Controller. To set the maximum volume, use the volume control knob found under the hatches on the tender.

### ***Adjusting the speed***

The **BRAKE** and **BOOST** buttons give you incremental control of your locomotive's speed while you press and hold these buttons, allowing you to make small, gradual adjustments around curves and over grades. The locomotive will resume its initial speed when the buttons are released. Listen for the squeal of your locomotive's brakes when you use the **BRAKE** button.



# ***TrainMaster Command Control operations***

## **Assigning your locomotive a new ID#**

---

**A**s your roster of TrainMaster Command Control-equipped locomotives grows, you will want to give each unit a unique ID#. The locomotive will respond to commands associated with its ID# while all other units will disregard these commands.

**Note!** To restore your locomotive's features, see page 18.

1. Slide the Command reverse unit switch on your locomotive to the PROG position. See Figure 3 on page 11.
2. Place the locomotive and tender on the track.
3. Connect the Command Base and plug it in.
4. Power up the track.
5. Press **ENG**.
6. Enter the unique ID#. Choose any number from 1 to 99 that has not been assigned to another locomotive (**ENG**). We recommend using a part of your locomotive's cab number.
7. Press **SET**. The locomotive's whistle will sound, or the headlights will flash if the RailSounds sound system is off.
8. Slide the Command reverse unit switch back to the RUN position.

The locomotive's ID# has been set. Be sure to record the new ID# for your reference.

# ***TrainMaster Command Control operations***

## **Reprogramming your locomotive to restore features**

---

If your locomotive is unresponsive to your commands in the TrainMaster Command Control environment, we recommend that you follow this procedure to reset your locomotive. All factory default settings will be restored when you reprogram the locomotive.

1. Slide the Command reverse unit switch to the PROG position.
2. Plug in and connect your Command Base.
3. Place your locomotive and tender on the track, then power up the track.
4. Press **ENG** and enter the locomotive's ID#.
5. Press **SET**.
6. Press **ENG** and enter the locomotive's ID# again.
7. Press **AUX1**.
8. Enter **1** for this particular locomotive.
9. Turn off track power and wait ten seconds.
10. Slide the Command reverse unit switch back to the RUN position.

At this point, your locomotive has been reset. Restore power to the track and operate the locomotive as usual. Be sure to use the ID# entered in Step 4.

# ***Conventional transformer operations***

## **Operating your locomotive in the conventional environment**

---

**Y**our locomotive is capable of operating in the conventional environment with nothing more than a standard Lionel alternating-current (AC) transformer.

In the conventional environment, your locomotive cycles through a repeating pattern of operations: forward, neutral, reverse, neutral, and so on. To advance to the next operation, press the **DIRECTION** button on your transformer. Alternately, you could use the throttle to briefly turn off track power so that the locomotive advances to the next operation when power is restored.

Once you cycle the locomotive into forward or reverse, you control your locomotive's speed by varying track voltage with the transformer's throttle. To increase the speed of the locomotive, you increase track voltage. To decrease the speed, you decrease track voltage. To stop the locomotive and to change directions (or to enter neutral), track voltage is turned off or interrupted.

Use the **HORN** and **BELL** buttons on your transformer to activate these features. If your transformer is not equipped with these controls, separate buttons are available (610-5906-001). Please refer to page 29 of this manual.

To experience all of your locomotive's features, we recommend operating in the LEGACY Command Control environment. With a simple one-wire connection, you can use the CAB-2 Remote Controller to access all of the functions of your locomotive. Refer to pages 5-10 to see how to operate your locomotive in the LEGACY Command Control environment.

# ***Conventional transformer operations***

## **Operating your locomotive in the conventional environment (continued)**

- 1. Place your locomotive on Lionel or Lionel-compatible 0-31 or larger track.**
- 2. Power your locomotive at 12-18 volts with your alternating current (AC) transformer.**

**Caution!** Power your locomotive with an alternating-current (AC) transformer only. Powering your locomotive with a direct-current (DC) transformer, or in excess of 19 volts AC, may result in damage to sensitive electronic components. 60 HZ AC is required. **Do not power with 50 HZ AC.**

- 3. Wait three to eight seconds as your locomotive determines whether it is in a conventional environment or a TrainMaster Command Control environment.**

When the locomotive has determined that a TrainMaster Command Base is not connected to the track, the locomotive's headlight will illuminate and the LEGACY RailSounds sound system will start. You are ready for operation in the conventional environment.

- 4. Move 'em out!**

Press the **DIRECTION** button on your transformer to sequence your locomotive through the repeating pattern of operations: forward, neutral, reverse, neutral, and so on. You may also briefly turn off track power to advance the locomotive to the next operating state. Adjust the throttle until your locomotive moves at your desired speed.

**Note!** When placing your locomotive on your layout for the first time, it will start out in neutral. Thereafter, it will start in forward after every power interruption lasting five seconds or longer.

**We recommend that you operate your LEGACY locomotive with The Odyssey II Speed Control System turned on.** You may choose to operate your locomotive without speed control by placing the Odyssey II Speed Control System switch to the OFF position. See Figure 3 on page 11.

Use the **HORN** and **BELL** buttons on your transformer to activate those features. Refer to page 28 if your transformer is not equipped with those buttons. Adjust the volume using the volume control knob located under the tender water hatch. Refer to Figure 5 on page 26.

# ***Conventional transformer operations***

## **Locking your locomotive into a single direction**

---

**W**hen the Command reverse unit switch is in the RUN position, your locomotive sequences through a repeating pattern of operations: forward, neutral, reverse, neutral, and so on.

To “lock” your locomotive into a single direction (for example, to operate in forward only), you can deactivate the Command reverse unit’s sequencing function.

1. Use your transformer’s **DIRECTION** button or interruptions in track power to get your locomotive moving in the desired direction or into neutral.
2. Slow the locomotive down without stopping (reduce the throttle without turning off track power).
3. Slide the Command reverse unit switch to the PROG position. At this point, the locomotive is “locked” into your chosen direction. See Figure 2 on page 11 for the location of this switch.

To restore the forward-neutral-reverse sequence, just slide the Command reverse unit switch back to the RUN position.

# Conventional transformer operations

## Uncoupling your locomotive in the conventional environment

---

**Y**our locomotive features an ElectroCoupler that is released by remote control at any point around your layout in the TrainMaster Command Control environment.

In the conventional environment, the ElectroCoupler will not open manually or by using a Remote-Control Track section. To couple your locomotive in the conventional environment, you must rely on a piece of rolling stock equipped with a magnetic coupler. Simply release the magnetic coupler and couple the rolling stock to the locomotive, even if the ElectroCoupler is closed.

Keep in mind that you may still make use of Lionel Remote-Control Track sections (6-65530 for O gauge; 6-12746 and 6-65149 for O-27 gauge; and 6-12020 and 6-12054 for FasTrack layouts) with the magnetic couplers on the rolling stock. Place the trigger disc on the magnetic coupler over the central coil on the Remote-Control Track section, then press UNCOUPLE on the track section's controller. As illustrated in Figure 4, the magnetic field pulls the disc downward, releasing the coupler.

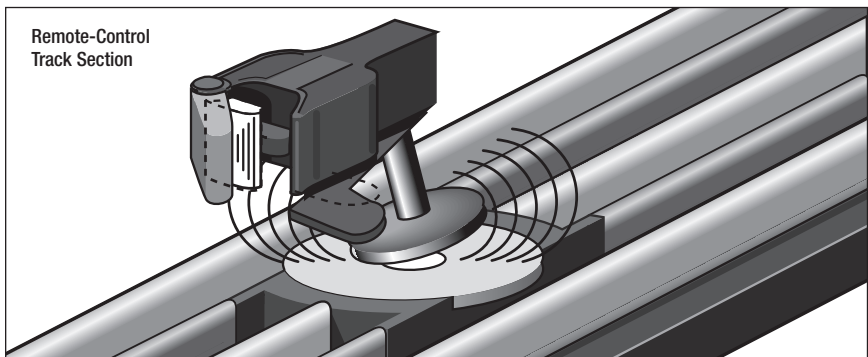

Figure 4. Magnetic coupler operation

# *Odyssey II Speed Control system operations*

## **Odyssey II Speed Control system operations**

---

**T**he Odyssey II Speed Control system is “cruise control” for your locomotive. Once the speed control is set, your locomotive will maintain a constant speed, no matter what load is placed on the locomotive or what grades you have on your layout. The Odyssey II Speed Control system also allows for extremely slow movement that will amaze any scale enthusiast.

## **Odyssey II Speed Control System LEGACY Control operation**

---

**I**n LEGACY Control System CAB-2 mode, Odyssey II Speed Control system provides 0-199 speed steps. For a more in depth explanation of the LEGACY Control System features, please see your LEGACY Control System operations manual.

## **Odyssey II Speed Control system TrainMaster Command Control operation**

---

**W**hen Odyssey II Speed Control system is activated, changes in the speed of the locomotive will correspond to each signal from the Command Base. For example, when you address the locomotive and slowly turn the throttle knob, the first flash of the red light on the Command Base corresponds to the first speed step, which is the slowest speed of the locomotive. The locomotive will maintain that speed until you increase or decrease the throttle.

In TrainMaster Command Control CAB-1 mode, Odyssey II Speed Control System now provides selectable resolution and momentum. L=32 speed steps, M= 100 speed steps, and H= 100 speed steps with momentum. See page 13.

## **Odyssey II Speed Control system conventional transformer operation**

---

**T**he Odyssey II Speed Control system is automatically operational when you operate your locomotive in conventional (non-Command Control) mode, as long as the Odyssey II Speed Control system switch is in the ODY position (see Figure 2 on page 11). This means that your locomotive will maintain a constant speed, compensating for grades, loads, and turns. Simply use your transformer’s throttle to adjust the speed of your locomotive.

**Caution!** In conventional operation, the lights in the locomotive are connected directly to track power. Do not exceed 14-16 volts for extended periods. Doing so will reduce the life of your lamps.

**Note!** Because of the way that speed control operates in conventional mode, you will notice a slight delay between adjusting your transformer throttle and the change in the speed of your locomotive. If you desire instantaneous response to throttle changes, turn off the Odyssey II Speed Control system using the Odyssey switch on the bottom of the locomotive.

# ***LEGACY RailSounds sound system operations***

## **LEGACY RailSounds sound system operations**

---

**Y**our locomotive is equipped with the Lionel LEGACY RailSounds sound system, the most realistic model railroad sound system in the world. The LEGACY RailSounds sound system brings the sounds of the railroad to your layout through high quality sound recordings of real locomotives.

When you operate your locomotive in the conventional environment, you get realistic chuffing sounds, which automatically increase through 15 levels as the speed of the locomotive increases. You can sound the locomotive's whistle or activate the ringing of the bell. When you are through with operations and power down the track, your locomotive's LEGACY RailSounds sound system starts a realistic steam shutdown sequence (a nine-volt battery is required for the operation of the LEGACY RailSounds sound system when the track is powered down).

When you operate your locomotive in the TrainMaster Command Control environment, you gain additional control of the LEGACY RailSounds sound system, including the whistle and bell sounds. The locomotive's chuffing sounds automatically increase, but you can also set a particular chuff intensity level using your CAB-1 Remote Controller. In the Command Control environment, the release of the ElectroCoupler is accompanied by a coupler release sound. Use the **BRAKE** button, and listen for the sound of squealing metal. You can also trigger CrewTalk dialog and TowerCom announcements, which simulate the interaction between the locomotive crew and the dispatcher. Whenever you choose to shutdown your locomotive, the realistic shutdown sequence commences (a nine-volt battery is required for the operation of the LEGACY RailSounds sound system when the track is powered down).

Operating your locomotive with the LEGACY Control system provides you control of all the features mentioned above as well as access to the new **quilling whistle** and **single hit bell** sounds.



# ***LEGACY RailSounds sound system operations***

## **Installing the battery**

---

**A**lthough the LEGACY RailSounds sound system is powered through the track, we recommend that you install a nine-volt alkaline battery in the tender to prevent the sound system from shutting down during track power interruptions (for example, at a switch or a dirty section of track). Follow these steps and refer to Figure 5 as you install the battery.

**Note!** If the RailSounds sound system turns off during interruptions in track power, you may need to replace the battery.

1. Remove the body screws from the underside of the tender. Refer to Figure 5 for the location of the screws.
2. Lift the body off the frame. Be careful to avoid pulling on the wires that connect the body to the frame.
3. Remove the protective cover from the battery harness.
4. Snap the battery harness onto the nine-volt alkaline battery's terminals.
5. Slide the battery into the battery holder.
6. Replace the body on the frame and secure it with the body mounting screws. Be careful to avoid pinching wires between the body and the frame.

# LEGACY RailSounds sound system operations

## Installing the battery (continued)

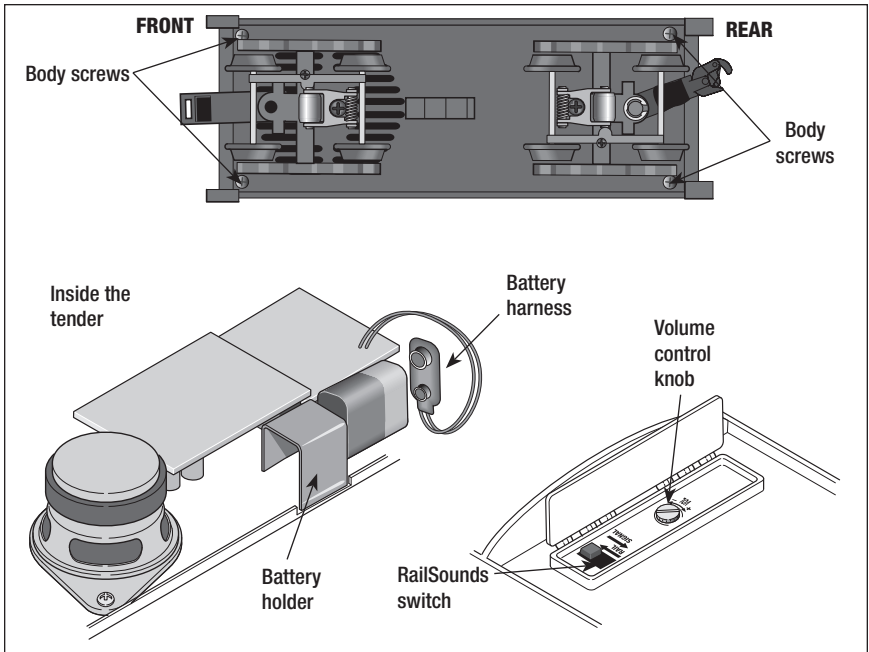

Figure 5. Installing the battery in the tender

# ***LEGACY RailSounds sound system operations***

## **Using the LEGACY RailSounds sound system in the TrainMaster Command Control environment**

---

**O**perating in the TrainMaster Command Control environment allows you access to many of the features of the LEGACY RailSounds sound system. The CAB-1 Remote Controller activates features such as TowerCom announcements, CrewTalk dialog, and coupler release sounds. Refer to pages 27, 28, 29 and 30 to learn how the LEGACY RailSounds sound system is integrated into TrainMaster Command Control operations.

**Note!** For proper operation of the LEGACY RailSounds sound system during track power interruptions and for the locomotive shutdown sequence, you must install a nine-volt alkaline battery. See pages 25-26.

In the TrainMaster Command Control environment, you will experience these features of the LEGACY RailSounds sound system. See page 14 to adjust the volume.

- **DynaChuff.** Your locomotive's speed automatically determines the level of chuffing sounds. At low speeds, the chuffing is relaxed. When you highball down the mainline, the chuffing intensity is labored. You may also manually set the chuff sounds to a particular level using your CAB-1 Remote Controller.
- **Whistle.** A different whistle sound at different speeds.
- **Authentic bell.** Press **BELL** on your CAB-1 Remote Controller to begin the effect, then press **BELL** a second time to discontinue the effect.
- **Squealing brakes.** Press the **BRAKE** button and listen for the squealing of the locomotive's brakes as the locomotive slows down.
- **Coupler release sounds.** Use your CAB-1 Remote Controller to release the ElectroCoupler, and you get the sounds of the coupler opening.
- **TowerCom announcements.** TowerCom announcements are a dispatcher-initiated radio conversation with the engineer. Depending on the movement of the locomotive, the dialog will change. The LEGACY RailSounds sound system will often use different words and phrases when composing the conversation.
- **CrewTalk dialog.** CrewTalk dialog is an engineer-initiated radio conversation with the dispatcher. Depending on the movement of the locomotive, the dialog will change. The LEGACY RailSounds sound system will often use different words and phrases when composing the conversation.
- **Reverse unit reset sound.** Power down your track, wait three seconds, and listen for the air-release sound—that's the locomotive telling you that its Lionel Command reverse unit has reset to forward. (A nine-volt alkaline battery is required.)
- **Shutdown sequence.** When you turn off track power, you have two seconds to power up again after you hear the reverse unit reset sound. If you do not restore power, you will hear the realistic shutdown sequence. Because track power is off, a battery is required for this sequence to function.

# ***LEGACY RailSounds sound system operations***

## **Using the LEGACY RailSounds sound system in the conventional environment**

---

**W**hen you first power up your locomotive, you will hear the sounds of the locomotive at rest. As the locomotive moves, the chuffing sounds automatically increase with the locomotive's speed. In the conventional environment, the whistle and bell sounds are activated by your transformer controls.

To silence the chuffing sounds, slide the LEGACY RailSounds sound system switch located under the hatch on top of the tender to the SIGNALSOUNDS position before you power up the locomotive or after the locomotive has been powered down for a minimum of ten seconds. The whistle and bell sounds will still be active. To adjust the volume, use the volume control knob located under the hatch on top of the tender.

**Note!** For proper operation of the LEGACY RailSounds sound system during track power interruptions and for the locomotive shutdown sequence, you must install a nine-volt alkaline battery. See pages 25-26.

In the conventional environment, you will experience several features of the LEGACY RailSounds sound system.

- **DynaChuff.** Your locomotive's speed automatically determines the level of chuffing sounds. At low speeds, the chuffing intensity is relaxed. When you highball down the mainline, the chuffing intensity is labored.
- **Whistle.** A different whistle sound at different speeds.
- **Authentic bell.** Press **BELL** on your transformer to begin the effect, then press **BELL** a second time to discontinue the effect.
- **CrewTalk dialog and TowerCom announcements.** These brief conversations between the train crew and the tower are triggered by short whistle blasts.
- **Reverse unit reset sound.** Power down your track, wait three seconds, and listen for the air-release sound, which is the locomotive telling you that its Lionel Command reverse unit has reset to forward. (A nine-volt alkaline battery is required.)
- **Shutdown sequence.** When you turn off track power, you have two seconds to power up again after you hear the reverse unit reset sound. If you do not restore power, you will hear the realistic shutdown sequence. Because track power is off, a battery is required for this sequence to function.

# LEGACY RailSounds sound system operations

## Installing a Lionel Sound Activation Button for conventional operation

If your transformer lacks **WHISTLE** and **BELL** buttons, you will need to install Lionel no. 610-5906-001 Sound Activation Buttons (available separately) to activate the locomotive's whistle and bell sounds.

Connect the buttons as shown below. Be sure that all track power passes through the Sound Activation Button(s). Do not bypass the buttons.

### For AC transformers lacking a bell button

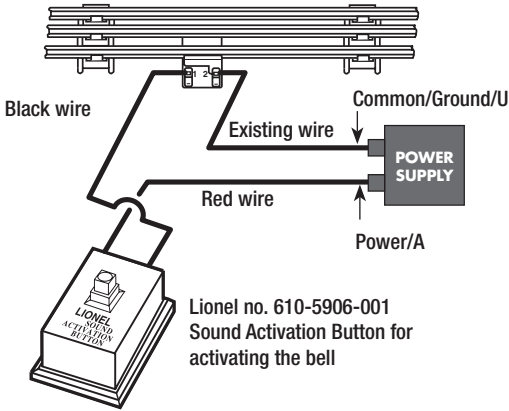

### For AC transformers lacking bell and horn/whistle buttons

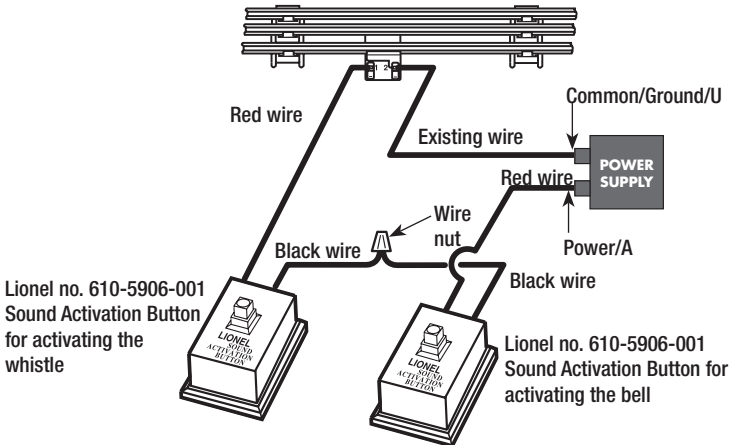

# ***LEGACY RailSounds sound system operations***

## **Activating the CrewTalk dialog and TowerCom announcements in the conventional environment**

---

In the conventional environment, CrewTalk dialog and TowerCom announcements are triggered by short whistle blasts and vary with the state of the locomotive.

- If the locomotive has been stopped for less than 15 seconds, a short whistle blast triggers a “please standby” dialog.
- If the locomotive has been stopped for longer than 15 seconds, a short whistle blast triggers a “cleared outbound” dialog.
- If the locomotive is moving, a short whistle blast triggers an “all clear ahead” dialog.
- If the locomotive is moving with the bell activated, a short whistle blast triggers a “slow to caution” dialog.

# Maintaining and servicing your locomotive

## Adding fluid to your locomotive's smoke generator

---

**Y**our locomotive is equipped with a smoke generator that produces a safe, clean, white smoke during operation. In order to function, the smoke generator requires the periodic addition of Lionel smoke fluid. A small bottle of smoke fluid is included with your locomotive.

To add smoke fluid, press down and unscrew the cap of the smoke fluid bottle. Pierce the top of the nozzle with a pin, then add 10 to 15 drops of fluid into the stack of your locomotive. It is easier to add smoke fluid if your locomotive is powered down or the smoke unit is off. Power up your locomotive with the smoke unit switch in the ON position, and smoke production will start momentarily. Smoke production will start faster if you operate your locomotive at higher speeds. Smoke production is greatest at high voltages and when the locomotive pulls a heavy load. When smoke production decreases, add four to eight additional drops of smoke fluid.

When the smoke unit switch is in the ON position, always keep a small amount of smoke fluid in the smoke unit. Operating your locomotive's smoke unit without smoke fluid will cause damage to the heating element.

If you prefer to operate your locomotive without smoke, locate the smoke unit switch on the underside of the locomotive and slide it to the OFF position. Refer to Figure 3 on page 11 for the location of this switch.

In the TrainMaster Command Control environment, press **AUX1, 8** on your CAB-1 Remote Controller to turn off the smoke unit. To turn on the smoke unit, be sure that the smoke unit switch is in the ON position, then press **AUX1, 9**.

**Caution!** Always operate your locomotive's smoke unit with the addition of smoke fluid to prevent damage to the heating element.

## Adjusting the smoke output

---

**Y**our locomotive features an improved smoke unit with variable smoke output. In the TrainMaster Command Control environment, you may select low, medium, or high smoke output using your CAB-1 Remote Controller. Your locomotive is shipped from the factory in the medium smoke output setting.

To adjust the smoke output, bring the locomotive to a stop, press **AUX1, AUX2, 9**, then press **L** for low smoke, **M** for medium smoke, or **H** for high smoke. Press **AUX2** again to complete the setting. See page 13 for the location of these buttons on the CAB-1 Remote Controller.

Your locomotive will remember its new setting until you change it again.

**Note!** It may take up to a minute for the smoke unit to heat up or cool down to the new setting.

**Note!** In the conventional environment, smoke output is always at the medium level. Smoke output is not variable in the conventional environment.

**Note!** Adjusting the variable smoke unit output using the **L, M, or H** buttons will also effect the locomotives speed step setting (see page 13). After changing the smoke unit output, simply reset the speed step setting to your preferred setting by pressing the **L, M, or H** button once again.

# Maintaining and servicing your locomotive

## Lubricating your locomotive

**H**elp your Lionel locomotive lead a long and productive life on your railroad by maintaining it properly. To keep your locomotive lubricated, we recommend that you purchase a Lionel Lubrication and Maintenance Kit (6-62927), available from your authorized Lionel dealer.

When you find that the lubrication points illustrated in Figure 6 appear dry, lubricate your locomotive after you have removed any accumulated dirt and dust. There are two basic rules to keep in mind when you are lubricating your locomotive: use only a small amount of lubrication and avoid getting grease or oil on your locomotive's wheels, roller pick-ups, or the track.

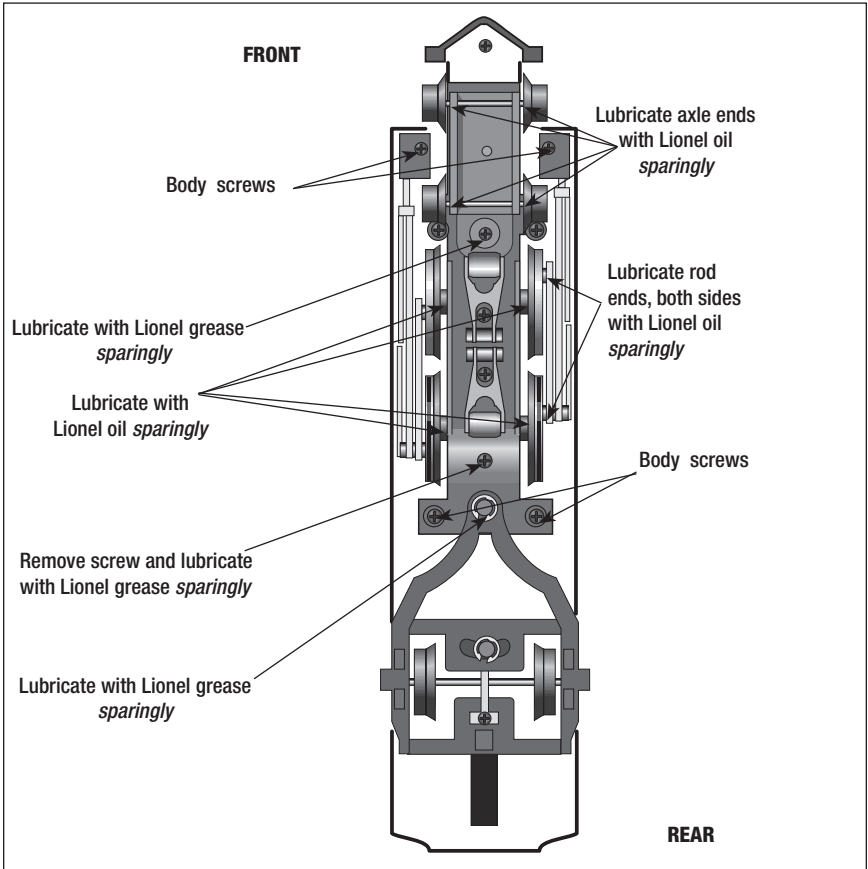

Figure 6. Lubrication points



# ***Maintaining and servicing your locomotive***

## **Maintaining your locomotive's handrail antenna**

---

**T**he handrails on your locomotive are the antennas that receive the digital communication from the Command Base. For optimum reception, the handrails have been insulated from the die-cast body. Please handle the locomotive carefully to avoid handrail damage. The handrails should not touch the locomotive's body.

If your locomotive appears to have problems receiving communications from the Command Base, be sure that the ends of the handrails are insulated from the body with either an insulating washer or handrail stanchion.

## **Servicing your locomotive's lamps**

---

**Note!** Before changing the lamps in your locomotive, be sure to check that the **AUX2** command was not used to turn off the front headlight.

**Y**our locomotive is illuminated by several lamps. One lamp is located in the headlight housing mounted on the boiler front. Another lamp illuminates the interior of the cab. During the course of normal operations, these lamps may require replacement.

Removing the screws as shown in Figure 6 on page 32 will allow access to the inside of the cab and the expired lamps. Due to the complexity of the required disassembly, we recommend that you take your locomotive to your authorized Lionel Service Center for any lamp replacement.

Lamp Numbers:	
Headlight (1)	620-8029-300
Cab light (1)	610-8082-019
Glowing Firebox	610-8082-019

**Note!** The two green classification lights and the tender marker lights are LEDs (light emitting diodes) and are not user serviceable. They can be replaced by your authorized Lionel Service Center, if it is ever required.

# ***Maintaining and servicing your locomotive***

## **Tire-Traction**

---

**Y**our locomotive is equipped with traction tires. This means that two of the drive wheels are fitted with rubber traction tires to enhance tractive effort so your locomotive can pull many cars at once.

Lionel has provided extra traction tires to replace the installed traction tires if they ever wear out. The traction tires are replaced by unscrewing the drive rod screws. Slip off the old traction tire and remove it from under the drive rod. Place the new traction tire on the wheel and re-tighten the drive rod screw.



## Limited Warranty/Lionel Service

---

**T**his Lionel product, including all mechanical and electrical components, moving parts, motors and structural components, except for light bulbs, is warranted to the original consumer-purchaser, for **one year** against original defects in materials or workmanship when purchased through an authorized Lionel merchant.

This warranty does NOT cover normal wear and tear, light bulbs, defects appearing in the course of commercial use, or damage resulting from abuse or misuse of the product by the purchaser. Transfer of this product by the original consumer-purchaser to another person voids this warranty. Modification of this product voids this warranty.

Any warranted product which is defective in original materials or workmanship and is delivered by the original consumer-purchaser to Lionel L.L.C. or an authorized Lionel L.L.C. Service Center, together with proof of original purchase will, at the option of Lionel L.L.C., be repaired or replaced, without charge for parts or labor. In the event the defective product cannot be repaired, and a replacement is not available, a refund of the original purchase price will be granted. Any products on which warranty service is sought must be sent freight or postage prepaid, as transportation and shipping charges are not covered by the warranty.

### **In no event shall Lionel L.L.C. be liable for incidental or consequential damages.**

Some states do not allow the exclusion or limitation of incidental or consequential damages, so the above exclusion may not apply to you.

This limited warranty gives you specific legal rights, and you may have other rights which vary from state to state.

### **Instructions for Obtaining Service**

If service for this Lionel L.L.C. product is required, bring the item, along with your dated sales receipt and completed warranty information to the nearest Authorized Lionel Service Center. Your nearest Lionel Service Center can be found by calling 1-800-4-Lionel, or by accessing our Website at [www.lionel.com](http://www.lionel.com).

If you prefer to send your product back to Lionel L.L.C. for repair in Michigan, you must first call 586-949-4100 or FAX 586-949-5429, or write to Customer Service, P.O. Box 748, New Baltimore, MI 48047-0748, stating what the item is, when it was purchased and what seems to be the problem. You will be sent a return authorization letter and label to ensure your merchandise will be properly handled upon receipt.

Once you have received your return authorization and label, make sure that the item is packed to prevent damage during shipping and handling. We suggest that you use the product's original packaging. This shipment must be prepaid and we recommend that it be insured.

Please make sure you have followed all of the above instructions carefully before returning any merchandise for service. You may choose to have your product repaired by one of our Authorized Lionel Service Centers after its warranty has expired. A reasonable service fee will be charged.

### **Warranty Information**

Please complete the information below and keep it, along with your dated sales receipt. You must present this and your dated sales receipt when requesting warranty service.

Name \_\_\_\_\_

Address \_\_\_\_\_

Place of Purchase \_\_\_\_\_

Date of Purchase \_\_\_\_\_

Product Number \_\_\_\_\_

Product Description \_\_\_\_\_



© 2008 LIONEL L.L.C., CHESTERFIELD, MI 48051-2493  
UNITED STATES OF AMERICA  
PRINTED IN CHINA