

73-7065-250
6/12

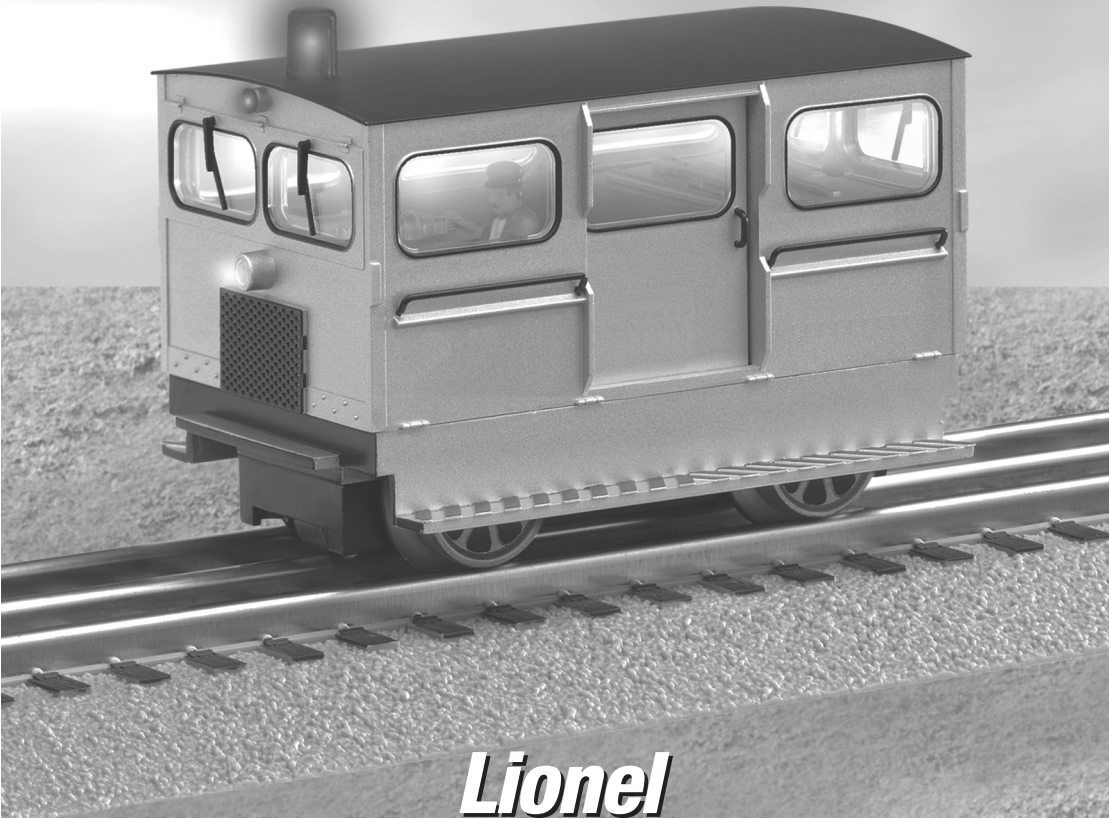

Lionel Railroad Speeder Owner's Manual

featuring **TRAINmaster.**
C·O·M·M·A·N·D

Congratulations!

Congratulations on your purchase of the Lionel Railroad Speeder! This motorized vehicle features a powerful maintenance-free motor. You can operate it in Command Control or Conventional mode. With plenty of scale details, your Railroad Speeder will look great on your layout.

Features of this vehicle

- **Command Control equipped**
- **Directional lighting**
- **Interior lighting**
- **Roof mounted flashing strobe light**
- **1:48 Scale**
- **Driver figure**
- **Window inserts**

The following Lionel marks are used throughout this Owner's Manual and are protected under law. All rights reserved.

Lionel® , LEGACY™ , FasTrack™ , TrainMaster® , Odyssey® , RailSounds® , CrewTalk™ , TowerCom™ , DynaChuff™ , StationSounds™ , Pullmor® , ElectroCoupler™ , Magne-Traction® , CAB-1® Remote Controller, American Flyer® , Lionel ZW® , ZW® , MagniVision® , TMCC® , Lionelville® , Wireless Tether™ , Powerhouse™ , LionMaster® , Conventional Classics™ , Postwar Celebration Series™ , TruRail™ , PH-1 Powerhouse® , Powermaster® , Powerstation-Powerhouse® , Accessory Motor Controller™ , AMC™ , Accessory Switch Controller™ , ASC™ , Action Recorder Controller™ , ARC™ , Track Power Controller 300™ , TPC 300™ , Track Power Controller 400™ , TPC 400™ , Block Power Controller™ , BPC™ , Operating Track Controller™ , OTC™ , FatBoy™ , Lionel Lines® , Joshua Lionel Cowen Series™ , Lockon® , TrainSounds™ , MultiHorn™ , MultiWhistle™ , Choo-Choo™

Table of contents

TrainMaster Command operations

The CommandControl environment	4
CAB-2/CAB-1 commands for your vehicle	5
Assigning your vehicle a new ID#	6
Reprogramming the Command reverse unit to restore features	6

Transformer operations

Running your vehicle with a Lionel transformer	7
Command Reverse Unit switch	8

Maintaining and servicing your vehicle

Lubricating your vehicle	9
Replacing your vehicle's lamps	10
Notes	11
Limited Warranty/Lionel Service	12

Command Control operations

The Command Control environment

Command Control is the advanced model railroad control system from Lionel. Command Control gives you the power to operate multiple Command-equipped vehicles *on the same track, at the same time*.

To operate in Command mode, you need a Command Base and a CAB Remote Controller. Find them both at your authorized Lionel retailer.

Note! When operating your Speeder in the LEGACY Command Control environment, you must use LEGACY software version 1.5 and select “R100” control mode setting.

1

Place your vehicle on Lionel or Lionel-compatible 0 gauge track.

- **Make sure track power is OFF before placing your vehicle on the track.**
- **Make sure your Lionel Command Base is plugged-in** and its communications wire is connected to the COMMON post on your Lionel transformer *or* the U terminal on any of your installed PowerMasters.
- Once positioned on the track, **increase track voltage to FULL** (no more than 19 volts). On PowerMasters, slide the CMD/CONV switch to CMD.

2

Address your vehicle using your CAB-2/CAB-1.

- **Press ENG and 1** on the numeric keypad of your CAB-2/CAB-1. This command is sent by the remote to the Command Base, which then translates your command into digital code. That code is sent around your railroad’s outside rails in the form of a digital “halo.” All Command-equipped Lionel engines listen to this digital communication, but they do not respond until they hear their individual ID number—in this case, “1.”
- **The digital language of TrainMaster Command—and not track power—controls the actions of Command-equipped Lionel engines.** Track power is simply like gasoline in the tank of your car—it gives you the power to go places, but it doesn’t tell you where to go or how fast to get there.
- **All Command-equipped vehicles come factory-programmed with an ID# of “1.”** To change the ID# of your vehicle, see page 6.

3

Move ‘em out!

- Throttle up or press any command button on the CAB-2/CAB-1. Your vehicle will respond to your every command. Read on.

Command Control operations

CAB-2/CAB-1 commands for your vehicle

The CAB-2/CAB-1 commands for the vehicle are outlined below.

THROTTLE

Turn the THROTTLE to the right to accelerate, left to decelerate.

AUX1, 0

Stops and resets the vehicle to the idle position; ready to start in the forward direction.

AUX1, 8

Turns the strobe light off.

AUX1, 9

Turns the strobe light on.

AUX2

Toggles the headlights on and off.

DIR

The DIR key is used to change the directional state of your vehicle. Use the DIR button to decelerate to a complete stop; turn the throttle up, and the vehicle will accelerate in the opposite direction. There is no neutral state.

BRAKE AND BOOST

The BOOST and BRAKE command buttons give you incremental control of speed and are the superior way to handle grades, gradual stops-and-starts, and more.

In the TrainMaster Command Control environment, the Boost and Brake keys will increase and decrease the speed of your vehicle only as long as the keys are held down.

When operating your Speeder with the LEGACY system, the Brake feature can be set to maintain the speed without reverting back to the previous set speed.

Note! These settings will be lost when you assign a new engine ID number.

HALT

Press **HALT** to shut down *all* PowerMaster electrical output on your railroad. Stops *all* Command-equipped Lionel vehicles in operation.

Note! Use **HALT** only in *emergency* situations.

Command Control operations

Assigning your vehicle a new ID#

As your fleet of Command-equipped Lionel vehicles grows, you'll want to give your vehicle a more individualized number. Your Speeder can be programmed as either an engine (**ENG**) or accessory (**ACC**). Choose any number between 1 and 98.

Set the vehicle's Command reverse unit switch to PGM (see Figure 1 on page 8). Plug in the Command Base and place the vehicle on track, then power up. Using your CAB-2/CAB-1, press **ENG** or **ACC**, the vehicle ID# that you select and then press the **SET** button on the remote. Set the Command reverse unit switch to RUN. Your vehicle is ready for operations with its all-new ID#.

We recommend that you choose an easy to remember ID# for your engine. You may choose any two-digit number that is not used by another engine. Write the number on a small piece of tape and put this on the underside of the unit to aid in remembering.

Reprogramming the Command reverse unit to restore features

Due to the inevitable derailments and static, it is possible that your Command reverse unit could someday lose its setup program. The symptom of this condition would be unresponsiveness in Command mode. This can be easily remedied by "reprogramming" your Command reverse unit using the following steps.

Note! Your Speeder can be programmed as either an engine (**ENG**) or accessory (**ACC**).

STEP 1: Move the Command Reverse Unit switch on your vehicle to the PGM position.

STEP 2: Plug in your Command Base.

STEP 3: Place the vehicle on track, then turn on power to your track.

STEP 4: Press **ENG** or **ACC** then input the vehicle's ID#. Press **SET**.

STEP 5: Turn off power to your track and wait ten seconds.

STEP 6: Remove the vehicle from your track, and move the Command Reverse Unit switch to the RUN position.

STEP 7: Place the vehicle back on track, then turn power on to the track.

STEP 8: Press **ENG** or **ACC** and the ID#, then operate as normal.

Transformer operations

Running your vehicle with a Lionel transformer

1 ***Place your vehicle on Lionel or Lionel-compatible 0 gauge track.***

2 ***Power up your vehicle with your transformer.***

Your vehicle is designed to operate on 7-18 volts alternating current (AC). Virtually all Lionel and Lionel-compatible alternating-current transformers are suitable.

Caution! **Do not power your vehicle with direct current (DC).** Damage to sensitive electronic components may occur.

Note! **When you first power up your track, the vehicle will wait between three and eight seconds** as it “listens” for digital language from the TrainMaster Command Base (available separately). When it has determined that it’s on a conventional (non-Command) railroad, the vehicle’s headlight will illuminate. At this point, the vehicle is in neutral. (This occurs when placing the vehicle on your railroad for the first time. Thereafter, it will start in forward following every three-second power interruption.)

3 ***Move ‘em out!***

Get your vehicle moving. Press the DIRECTION button on your Lionel transformer. This sequences the Command reverse unit to the next operating state.

Adjust track voltage until your vehicle moves at your desired speed. To increase speed, increase track voltage. To decrease speed, reduce voltage. To stop the vehicle, turn-off track power, or cycle it to neutral.

Transformer operations

Switch overview

Use the Command Reverse Unit Switch to “lock” your vehicle in a single direction, or neutral, in the Conventional environment when the switch is placed in the PGM position. See Figure 1 below.

Also, the switch is used to assign an ID# and reprogram the vehicle in Command operation when the switch is in the PGM position.

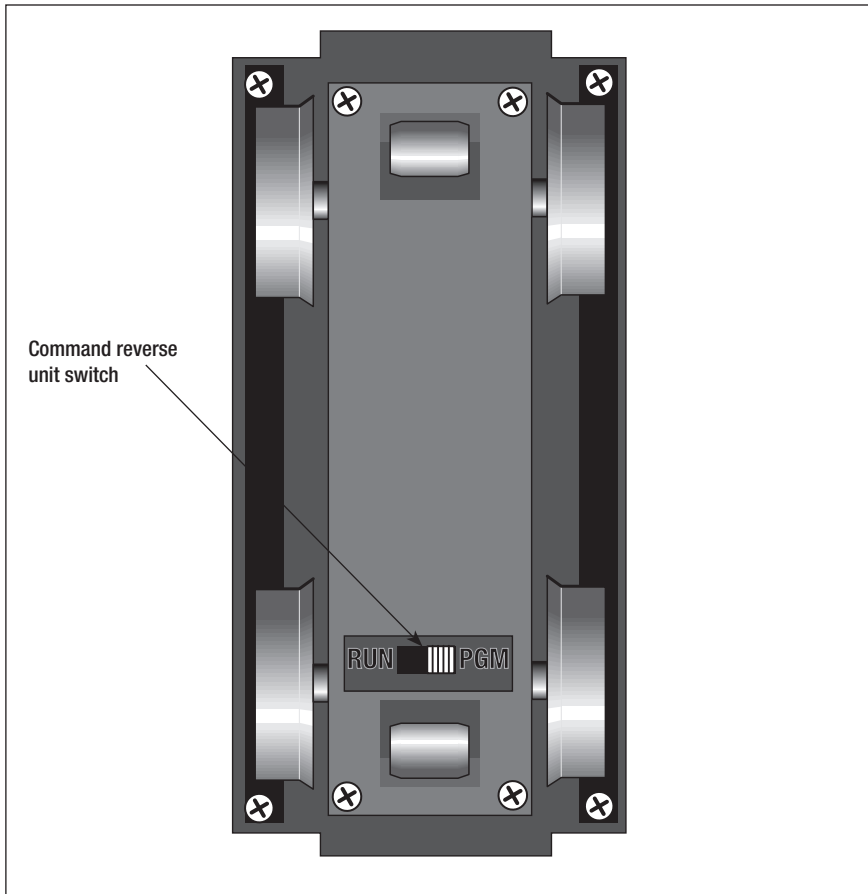

Figure 1. Command Reverse Unit switch

Maintaining and servicing your vehicle

Lubricating your vehicle

Help your Lionel vehicle lead a long and productive life on your railroad by maintaining it properly.

We recommend that you purchase a Lionel Lubrication and Maintenance Kit (no. 6-62927), available from your Lionel dealer. Two basic rules to keep in mind: *never* over-lubricate (a small amount will do), and avoid getting grease or oil on the vehicle's wheels *or* your track. You'll know your vehicle requires lubrication when visual inspection reveals dryness on the parts indicated in Figure 2 below. Remove accumulated dirt and dust before lubricating, and always lubricate any vehicle emerging from prolonged storage.

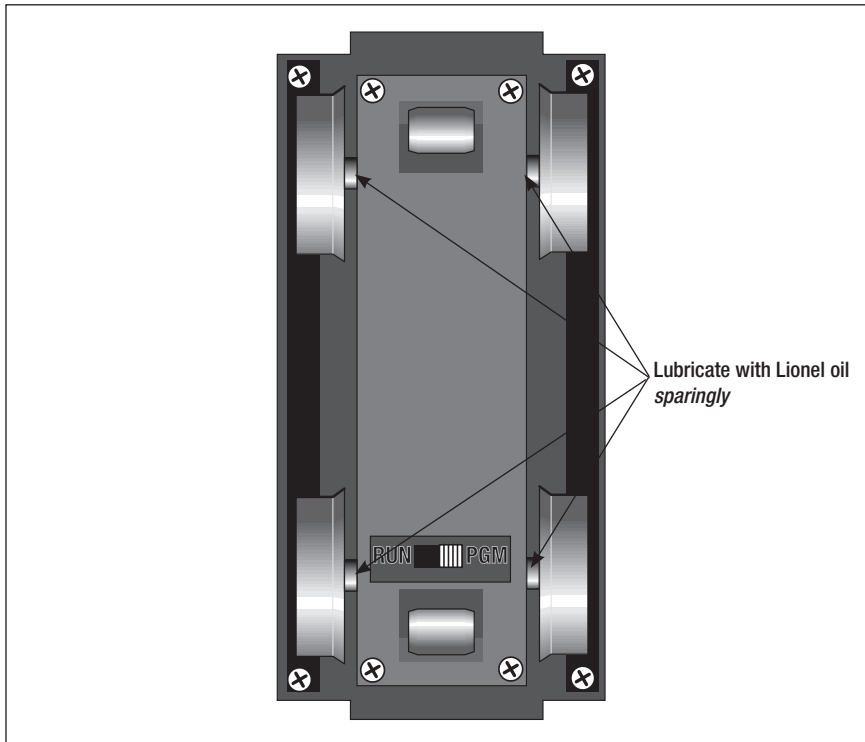

Figure 2. Underside details and lubrication points

Maintaining and servicing your vehicle

Replacing your vehicle's LEDs

Note! Before having the headlamp in your vehicle serviced, be sure to check that the **AUX2** command was not used to turn the headlamp off.

Your vehicle is illuminated by several LEDs that are expected to last for the life of the vehicle. The LED's are not user serviceable. If service is required, we recommend that you have your vehicle serviced at a Lionel Factory Trained Authorized Service Station.

Maintaining and servicing your vehicle

Notes

Lionel Limited Warranty Policy & Service

This Lionel product, including all mechanical and electrical components, moving parts, motors and structural components, with the exception of **LIGHT BULBS, LED's & TRACTION TIRES** are warranted to the original owner-purchaser for a period of **one year from the original date of purchase** against original defects in materials or workmanship when purchased through a **Lionel Authorized Retailer***.

This warranty does **NOT** cover the following:

- Normal wear and tear
- Light bulbs or LED's
- Defects appearing in the course of commercial use
- Damage resulting from abuse/misuse of the product

Transfer of this product by the original owner-purchaser to another person voids this warranty in its entirety. Modification of this product in any way; visually mechanically or electronically, voids the warranty in its entirety.

Any warranted product which is defective in original materials or workmanship and is delivered by the **original owner-purchaser** (this warranty is non-transferrable) to Lionel LLC or any Lionel Authorized Service Station **MUST** be accompanied by the original receipt for purchase (or copy) from an **Authorized Lionel Retailer***, will at the discretion of Lionel LLC, be repaired or replaced, without charge for parts or labor. In the event the defective product cannot be repaired, and a suitable replacement is not available, Lionel will offer to replace the product with a comparable model (**determined by Lionel LLC**), if available. In the event a comparable model is not available the customer will be refunded the original purchase price (requires proof of purchase from the **Authorized Lionel Retailer*** it was originally purchased). Any products on which warranty service is sought must be sent freight or postage prepaid (Lionel will refuse any package when postage is due). **Transportation and shipping charges are not covered as part of this warranty.**

NOTE: Products that require service that do not have a receipt from an LIONEL AUTHORIZED RETAILER* will be required to pay for all parts required to repair the product (labor will not incur a charge) providing the product is not older than 3 years from date of manufacture and is within 1 year from date of purchase. A copy of the original sales receipt is required.

In no event shall Lionel LLC be held liable for incidental or consequential damages.

Some states do not allow the exclusion or limitation of incidental or consequential damages, so the above exclusion may not apply to you.

This warranty gives you specific legal rights and you may have other rights which vary from state to state.

Instructions for Obtaining Service

If service for this Lionel LLC product is required; bring the item, along with your DATED sales receipt and completed warranty information (at the bottom of this page) to the nearest Lionel Authorized Service Station. Your nearest Lionel Service Station can be found by calling 1-800-4-LIONEL or by accessing the website at www.lionel.com.

If you prefer to send your Lionel product directly to Lionel, for repair you must FIRST call 586-949-4100 extension 9105 or FAX Lionel at 586-949-5429 or write to Customer Service, 26750 Twenty Three Mile Road, Chesterfield, MI 48051-2493. Please have the 6-digit Lionel product number, the date of original purchase, the dealer where the item was purchased and what seems to be the problem. You will receive a return authorization (RA) number to ensure your merchandise will be properly tracked and handled upon receipt at Lionel LLC.

Once you have your Return Authorization (RA) number, make sure the item is packed in its original Styrofoam inner container which is placed inside the original outer display box (this will help prevent damage during shipping and handling). This shipment **MUST** be prepaid and we recommend that it be insured with the carrier of your choice.

Please make sure you have followed all of the above instructions carefully before returning any merchandise for service. You may choose to have your product repaired by one of Lionel LLC's Authorized Service Stations after its warranty has expired. A reasonable service fee should be expected once the product warranty has expired.

Warranty Information

Please complete the information below and keep it, along with your **DATED ORIGINAL SALES RECEIPT**. You **MUST** present this form **AND** your **DATED SALES RECEIPT** when requesting warranty service.

*A complete listing of Lionel Authorized retailers can be found by calling 1-800-4-LIONEL or by visiting our website at www.lionel.com.

Products that are more than 3 years old, from date of manufacture, are not applicable for warranty coverage, even if they have never been sold prior to this date. (Under no circumstance shall any components or labor be provided free of charge.)

Name _____

Address _____

Place of Purchase _____

Date of Purchase _____

Product Number _____

Product Description _____



© 2012 LIONEL L.L.C., CHESTERFIELD, MI 48051
UNITED STATES OF AMERICA
PRINTED IN CHINA