

20231460250
7/22



***Lionel
VISIONLINE Class A
Steam Locomotive
Owner's Manual***



Thank You!

Thank you for your purchase of the Lionel VISION Class A! This engine is packed full of fun and innovative features only seen in Lionel VisionLine! We highly recommend that you take the time to thoroughly read this manual to familiarize yourself with all of the amazing features that this locomotive has to offer.

FCC Statement

This device complies with Part 15 of the FCC Rules and with Industry Canada license-exempt RSS standard(s). Operation is subject to the following two conditions: (1) This device may not cause harmful interference, and (2) This device must accept any interference received, including interference that may cause undesired operation.

Contains

P/N: BM832(A)

FCC ID: X8WBM832

IC ID: 4100A-BM832

Contents of your locomotive box

- 1 VISION Class A Locomotive
- 1 VISION Class A Tender
- 1 Smoke Fluid Funnel
- 1 Wrench
- 4 Replacement Traction Tires
- 1 Owner's Manual

The Bluetooth® word mark and logos are registered trademarks owned by the Bluetooth SIG, Inc. and any use of such marks by Lionel is under license. Other trademarks and trade names are those of their respective owners.

Apple and the Apple logo are trademarks of Apple Inc., registered in the U.S. and other countries. Mac App Store is a service mark of Apple Inc.

Google Play and the Google Play logo are trademarks of Google Inc.

The following Lionel marks are used throughout this Owner's Manual and are protected under law. All rights reserved.

Lionel, LionChief, LionChief Plus, FlyerChief, TMCC®, LEGACY®, FasTrack, TrainMaster, Odyssey, RailSounds, CrewTalk, TowerCom, ElectroCoupler, CAB-1 Remote Controller, TMCC, Wireless Tether, SensorTrack, DynaChuff, MultiWhistle



LEGACY® Control System

This revolutionary control system allows you to run your LEGACY Control System-equipped locomotive just like a real engineer runs his trains. With its enhanced sounds and 200 speed steps, this system allows properly equipped engines to function with unparalleled options. The CAB-2 Remote Controller has an LCD screen display, vibration that simulates the effort of the locomotive, and other exciting operating features. The new CAB-IL Remote Controller is a simplified alternative to unlock many LEGACY features.



ODYSSEY II® Speed Control

Slow speed and start-up operation are smooth and steady with ODYSSEY II Speed Control. Watch your locomotive as it creeps through the yard or fights up a grade without hesitation.



LEGACY® RailSounds®

Widely regarded as the industry standard, the impressive RailSounds sound system brings the real sounds of the railroad to your layout. From the mechanical symphony of the locomotives, to the commotion of the station, you will be impressed by the digitally recorded samples of these special and authentic sounds.



LionChief® Bluetooth®

Incorporating Bluetooth technology into Lionel model trains opens a new world, integrating the tradition of model railroading with the latest smart-device technology. With Lionel's new LionChief app, you can control full operation and sounds directly from your Bluetooth-enabled smart phone or tablet and operate multiple locomotives from the same device. LionChief is available to smartphone users and is compatible with all new 2017 to current LionChief, LionChief Plus, S-Gauge, and HO Trains.



Lionel Voice Control

Simply speak a command into your phone via your LionChief app and watch as your engine follows your lead! The Lionel Voice Control feature is available on all new and previously produced Bluetooth equipped engines.



4-Digit Addressing

Using the Base3 and Cab3 App, your locomotive is no longer limited to an address of 1 through 99. Assigning a 3 or 4-digit ID allows you to expand your locomotive roster without having to double-up numbers across multiple engines. It also allows you to use longer road numbers as IDs to help you remember the number assigned to the engine!

Table of Contents

Running your locomotive

Powering your locomotive	6
LEGACY Control operations	6
TrainMaster Command Control (TMCC/Command Control) operations	7
Conventional transformer operations	8

Locomotive basics

Locomotive switch locations	9
Locomotive Drop Plate	10
Adding smoke fluid to your locomotive's smoke generator	11
Assigning your locomotive a new ID# (LEGACY and TMCC)	12

Controlling your VISION features

To apply the Whistle Steam feature	13
To apply the Pop-off steam effect	13
Wheel Slip features	14
Force Coupler labor feature	15
4-Digit Addressing	16
BiColor Classification Lights Operation	17

LEGACY Control System operations

Lash-ups (for LEGACY operation only)	18
The LEGACY CAB-2 Remote Controller	19
The Velocity Throttle	20
The Multi-Controller	20
The Train Brake Slider	20
The Warning Sound Controller	21
The Speed Bar	21
EFX Trim and EFX Bar Graph	22
Leaving the Preset Speed Screen	22

LEGACY RailSounds Sound System operations

LEGACY RailSounds sound system	23
LEGACY RailSounds Sequence Control	24
CrewTalk dialog and TowerCom announcements in the LEGACY environment	25
Dual Sounds	26

Using the Bluetooth LionChief App

Connecting your Bluetooth-equipped locomotive on Apple devices	27
What if my Bluetooth enabled engine didn't automatically connect?	28
Connecting your Bluetooth-equipped locomotive on Android devices	29
Running Your Locomotive	30
Settings	31
Volume Control	31
Switching Connection Between Multiple Bluetooth [®] Locomotives	32
Lionel Voice Control	33-34
Troubleshooting	35

Table of Contents continued

Using the LionChief Universal Remote

The LionChief Universal Remote (6-83071)	36-37
Adjusting the locomotive volume using the Universal Remote	38
Pairing locomotives to the Universal Remote	38
Operating locomotives with the Universal Remote	39-40

TrainMaster Command Control operations

CAB-1 Remote Controller commands	41
CAB-1 Remote Controller numeric keypad commands	42-43
Setting the smoke level	43

Conventional transformer operations

Using the LEGACY RailSounds sound system in the conventional environment	44
Locking your locomotive into a single direction	44

Maintaining and servicing your locomotive

Reprogramming your locomotive to restore features	45
Lubricating your locomotive and tender	46
Servicing your locomotive's LEDs	47
Replacing the traction tires	47
Locomotive diagnostics	47
Lionel Warranty	48

Running your locomotive

Note! Your locomotive requires Lionel or Lionel-compatible O-72 or larger track curves.

Powering your locomotive

Your locomotive is designed to work with either AC or DC power.

AC Power: Use an alternating-current (50-60Hz AC) transformer for Legacy, Bluetooth, or Conventional control. Powering your locomotive in excess of 19 volts AC may result in damage to sensitive electronic components.

DC Power: Use a DC transformer for Bluetooth control only. Your locomotive is not designed to operate with Legacy or conventional control while using DC power. Powering your locomotive in excess of 19 volts DC may result in damage to sensitive electronic components.

LEGACY Control operations (AC power only)

For the finest operating experience, your locomotive is fully compatible with the LEGACY Control System.

To operate in LEGACY mode, you need a LEGACY Command Base and LEGACY CAB-2 Remote Controller (6-14295).

Your commands are sent by the CAB-2 Remote Controller to the Command Base, which sends a digital code through the rails to your locomotive. Your locomotive will not respond until it recognizes its unique ID#, so you can operate multiple Command-equipped locomotives on the same track at the same time.

1. Turn off track power, and then plug in the LEGACY Base and connect it to the track.
2. Place your locomotive and tender on the track and connect the drawbar as shown in Figure 1.
3. Increase track power voltage to full power (no more than 19 volts AC). If a circuit breaker trips when you turn on the Lionel power supply, check the wheels of your locomotive to make sure they are all securely on the track. Check to make sure the track is free of all metals that may cause a short circuit.
4. As illustrated in Figure 2, press ENG and 1 (or your selected ENG ID#) to address the locomotive with your LEGACY CAB-2 Remote Controller.

5. Press the Start Up button on your LEGACY CAB-2 Remote, shown in Figure 3. Then, throttle up and move 'em out! Your engine sound will start up, and the locomotive-specific touch screen buttons will populate the remote. For more information on operating your locomotive with the LEGACY system, please refer to the LEGACY section of this manual. Additional information is also found in the LEGACY System Manual, available online at www.lionel.com.

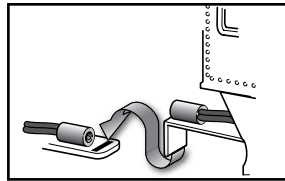

Figure 1. Drawbar connection

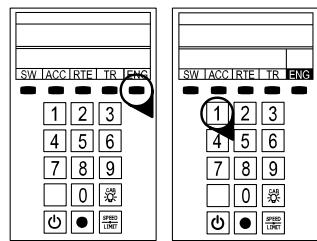

Figure 2. LEGACY engine selection

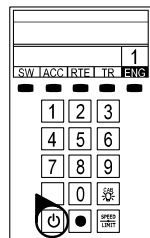

Figure 3. LEGACY start-up

Running your locomotive

Note! Your locomotive requires Lionel or Lionel-compatible 0-72 or larger track curves.

TrainMaster Command Control (TMCC) operations (AC power only)

For operation in the TrainMaster Command Control environment, you need a TrainMaster Command Base (6-12911) and a CAB-1 Remote Controller (6-12868). Refer to your TMCC System Manual for complete information. **To access all the locomotive's features, you must operate in the LEGACY environment, as discussed on the previous page.**

Your commands are sent by the CAB-1 Remote Controller to the Command Base, which translates the command into digital code. That code is sent through the outside rails to your locomotive, which will not respond until it recognizes its unique ID#. TrainMaster Command Control gives you the power to operate multiple Command-equipped locomotives on the same track at the same time.

- 1. Turn off track power, and then plug in the Command Base and connect it to the track.**
- 2. Place your locomotive and tender on the track and connect the drawbar as shown in Figure 1 on page 6.**
- 3. Increase track voltage to full power (no more than 19 volts AC).** If a circuit breaker trips when you turn on the Lionel power supply, check the wheels of your locomotive to make sure they are all securely on the track. Check to make sure the track is free of all metals that may cause a short circuit.
- 4. Press ENG and 1 (or the ENG ID# you set) to address your locomotive with your CAB-1 Remote Controller.**
- 5. Throttle up and move 'em out.**

For more information, please refer to the TrainMaster Command Control operations section of this manual or the TMCC System Manual, available online at www.lionel.com.

Running your locomotive

Conventional transformer operations (AC power only)

Note! For Conventional operation, a Command Base must not be powered up anywhere in the area, even if it is not connected to the track. If a base is detected, your locomotive will default to Command mode.

Note! Your locomotive requires Lionel or Lionel-compatible 0-72 or larger track curves.

1. **With track power off, place your locomotive and tender on the track. Connect the drawbar as shown in Figure 1 on page 6.**
2. **Power up the track.** If a circuit breaker trips when you turn on the Lionel power supply, check the wheels of your locomotive to make sure they are all securely on the track. Check to make sure the track is free of all metals that may cause a short circuit.
3. **Move ‘em out!** When the locomotive’s headlight illuminates and the LEGACY RailSounds sound system starts, press the DIRECTION button on your transformer to sequence your locomotive through the repeating pattern of operations: neutral, forward, neutral, reverse, neutral, and so on. You may also briefly turn off track power to advance the locomotive to the next operating state. Adjust the throttle until your locomotive moves at your desired speed.

Note! When placing your locomotive on your layout for the first time and after power interruptions lasting longer than five seconds, it will start out in neutral.

Use the **WHISTLE** and **BELL** buttons on your transformer to activate those features. For more information, please refer to the Conventional transformer operations section of this manual.

Locomotive basics

Locomotive switch locations

The functions of your engine's switches are outlined below. Refer to Figure 4 for the location of the switches. *The instructions below are specific to this particular locomotive; note that available features (and switches) may differ from other locomotives and sets.*

Bluetooth Switch

Used to turn the Bluetooth feature in the engine on and off.

Program / Run Switch

Used to assign an ID# and reprogram the locomotive in LEGACY and Command operation when the switch is in the PROG position. Also used to "lock" your locomotive in a single direction, or neutral, in conventional operation when the switch is placed in the PROG position.

Main Smoke Switch

Used to turn the stack smoke unit on and off.

Whistle Steam Switch

Used to turn the whistle smoke unit on and off.

Pop-off Steam Switch

Used to turn the Pop-off (Safety Steam) smoke unit on and off.

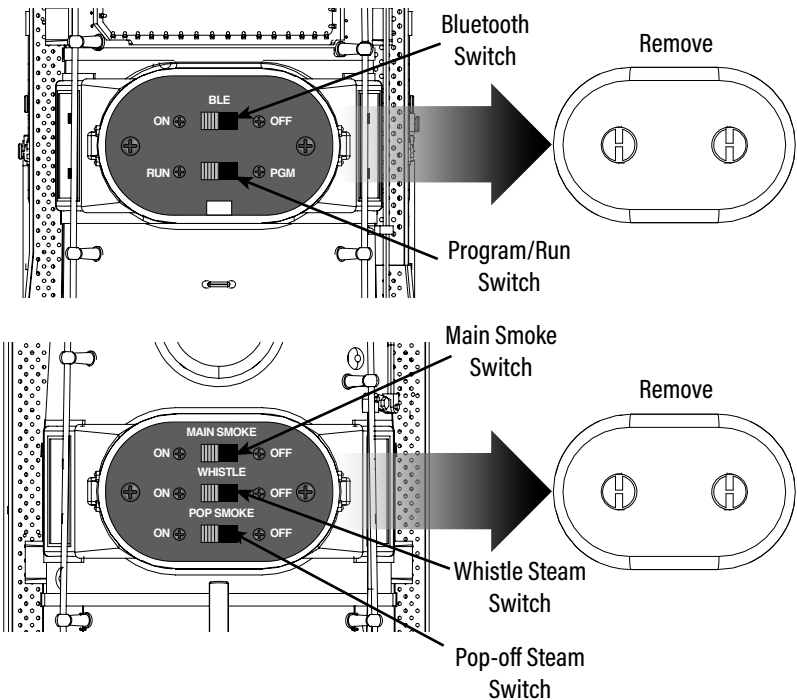

Figure 4. Locomotive switch locations, under both sand domes

Locomotive basics

Locomotive Drop Plate

The VISION Class A includes a Drop Plate that bridges the gap between the Locomotive's cab and the front of the tender. Use caution when connecting the locomotive's drawbar to the tender's drawbar. The Drop Plate should sit on top of the front detail on the tender. When storing the locomotive, make sure nothing is pressed up against the Drop Plate to avoid damage.

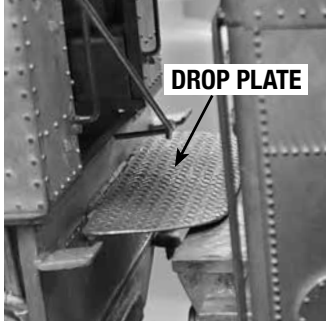

Figure 5. Drop Plate

Locomotive basics

Adding fluid to your locomotive's smoke generators

Your VISION Class A is equipped with three smoke generators that produce safe, clean, white smoke during operation. The smoke generators for this locomotive supply the stack, whistle steam, and pop-off steam smoke effects. The reservoirs contain the fluid and wicks which, once saturated, supply the heating elements with the right amount of fluid.

Note! For best performance, we recommend using only Lionel Premium Smoke Fluid.

Stack and Pop-off Smoke

Loading smoke fluid into the smoke stack will provide smoke fluid for the stack smoke effect and pop-off smoke effect. **When adding fluid DO NOT EXCEED 20 DROPS** as this can cause your smoke unit to become oversaturated allowing leakage onto the electronics. Note that operating your locomotive's smoke unit without smoke fluid will cause damage to the heating element. Add 20 drops initially and 10 to 20 thereafter, as required to maintain desired smoke.

Whistle Steam

The fill port for the whistle steam smoke unit is the same hole where the whistle steam exits from the top of the boiler. **When adding fluid DO NOT EXCEED 20 DROPS** as this can cause your smoke unit to become oversaturated allowing leakage onto the electronics. Note that operating your locomotive's smoke unit without smoke fluid will cause damage to the heating element. Add 20 drops initially and 10 to 20 thereafter, as required to maintain desired smoke.

Note! Your locomotive's smoke fluid consumption will vary depending on the smoke level setting you have selected and the labor of the locomotive.

Refer below as you add the smoke fluid. If you prefer to operate your Vision Steam Locomotive without smoke, locate the smoke unit switches under the sand domes on top of the boiler and slide them to the OFF position. Refer to Figure 4 on page 9 for the locations of the switches.

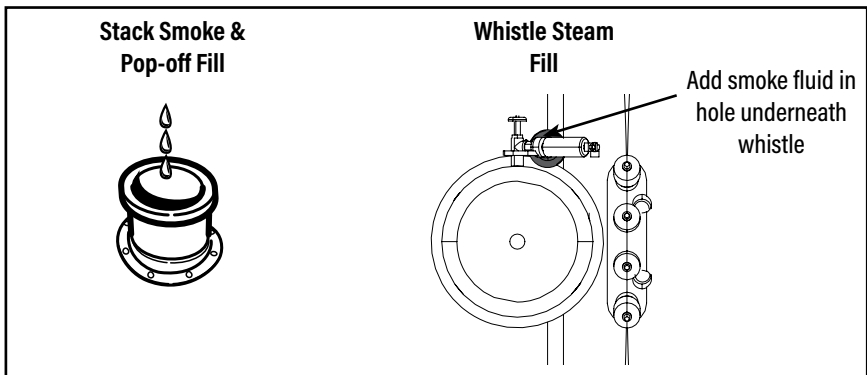

Figure 6. Smoke fluid fill locations

Locomotive basics

Assigning your locomotive a new ID#

For operation in the LEGACY or Command Control environment, you will want to give your Legacy Steam Locomotive a unique ID#. Your locomotive will respond to commands associated with its ID# while all other units will disregard these commands. ***This procedure is not necessary for Bluetooth or conventional (non-Command) operation.***

1. Slide the program run switch on your locomotive to the PGM position. See Figure 4 on page 9.
2. Place the locomotive on the track.
3. Connect the Command Base and plug it in.
4. Power up the track.
5. Press ENG on the CAB-1 or CAB-2 remote.
6. Enter the unique ID#. Choose any number from 1 to 98 that has not been assigned to another locomotive (ENG). We recommend using a part of your locomotive's road number.

Note! All LEGACY locomotives respond to ENG 99. We recommend that you reserve ID# 99 as a "universal" ID#.

7. Press SET. The locomotive's whistle will sound, or the headlights will flash if the RailSounds sound system is off.
8. Slide the program run switch back to the RUN position.
The locomotive's ID# has been set. Be sure to record the new ID# for your reference.

Controlling your VISION features

To apply the Whistle Steam effect

Stream will emerge from the whistle whenever the whistle is sounded. To activate this feature, use the whistle slider or button on any CAB controller, Universal Remote, or conventional transformer.

To apply the Pop-off Steam effect

The pop-off steam effect simulates the prototype's safety valves that would keep the boiler from over-pressurizing. The effect is located on the top of the boiler, near the middle. To load the smoke unit with smoke fluid, follow the instructions on page 11. A corresponding "woosh" sound plays with the effect.

The Pop-off steam effect only works when the engine's smoke units are turned on. Make sure the switch is in the ON position (see figure 4 on page 9) and then turn the smoke on using a CAB controller. If the smoke switch is turned off, both the smoke effect and the sound effect will be disabled. If the switch is in the ON position, but the smoke is turned off using a CAB controller, the smoke effect will be off, but the sound effect will still play.

There are two methods of running the Pop-off steam effect:

1. **Automatically:** The effect will operate when the engine is stopped and for a short time after it starts moving. The effect is programmed to run on a timer. This way it simulates real-life safety valves.
2. **Manually:** You can trigger the effect (both smoke and sound) manually by pressing the AUX3 button on the Cab2 remote. Note that to get the AUX3 button, the remote must be updated with Legacy version 1.60 minimum.

Note! Remember to never have the smoke unit running without having smoke fluid in it! This can damage the heating element.

To disable the Pop-off Steam feature, move the switch to the OFF position. See figure 4 on page 9 for switch location.

Controlling your VISION features

Wheel Slip features

To create the effect of a locomotive losing traction, your VISION Class A has a simulated slip feature which simultaneously produces smoke, sound, and motion. During wheel slip, the stack smokes as chuffing sounds rapidly increase, then decrease in speed and labor. This feature can be triggered when the locomotive motion starts.

Wheel slip can be triggered in two ways:

Trigger the wheel slip effect using the Boost key:

1. On a CAB-1 remote press the H button, or on a CAB-2 remote press the M or H buttons.
2. With the locomotive stopped, apply the boost key.
3. Adjust the throttle to maintain motion, as releasing the boost key stops the locomotive.

OR

Trigger the wheel slip effect using the Train Brake & Throttle (CAB2 only):

1. With the locomotive stopped or in motion, fully apply the train brake.
2. Turn or confirm the throttle position so the target speed is greater than zero.
3. Release the Train Brake slider by moving it upwards.

Controlling your VISION features

Force Coupler labor feature

The chuff is one of the hallmark sounds of a steam locomotive. The chuffing in a real steam engine can change intensity based on the load it's pulling. Legacy engines have been able to replicate that by manually adjusting the EFX rate in the Cab2 or by using the Train Brake.

Now that feature is done automatically, force-sensing technology is installed on the rear truck of the locomotive and relays data to the main processor. The processor determines the load on the engine and adjusts the chuff intensity and smoke output accordingly. If the engine is pulling a number of cars on a flat grade and then transitions to an incline, you'll hear the chuff intensity deepen and notice a slightly higher output of smoke. Inversely, when the engine begins to decline a grade, the labor sounds will get lighter, simulating a lighter load on the locomotive.

The force-sensing technology is very accurate and sensitive. Not only can it detect changes in load from grades and changes from adding or removing cars, but even small load changes caused by transitioning from straight to curved track sections or resistance felt in switch frogs. It's a great way to see where your engine works its hardest on your layout!

Aside from the force sensors changing the labor sounds, they can also detect a spike in force. This is called a CRUNCH. When a CRUNCH is detected, a loud "BANG" sound will play to simulate an instance such as an engine coupling to freight cars. The CRUNCH is tuned in a way that it typically is not activated during slow speed couplings or when a small number of cars are being coupled to. It takes a good amount of force from speed or a heavy load to create such a loud "BANG"! The engine can also detect a CRUNCH event when not moving. This would simulate another engine coupling to it for example.

Note! When the Force Coupler feature is enabled, the labor cannot be changed from the Cab2 remote. The EFX buttons will not have an effect on the chuff intensity.

You can disable the Force Coupler feature if desired. This is done when setting the engine's TMCC ID. After pressing SET but before moving the RUN/PGM switch back to RUN:

Cab-1/CabL: Press "AUX1" -> "8". Slide the RUN/PGM switch back to RUN.

Cab-2: Press "INFO"-> "AUX"-> "AUX1" -> "8". Then slide the RUN/PGM switch back to RUN.

When you press the 8 key, the engine will toot its whistle to acknowledge that it received the command to disable the Force Coupler.

With the Force Coupler feature disabled, the labor rate will not change automatically and there will be no CRUNCH effect. You'll be able to manually adjust the labor using the EFX buttons.

Note! To have the Force Coupler feature enabled again, follow the steps on page 12 to program the engine and slide the RUN/PGM switch back to RUN without doing any of the above steps.

Controlling your VISION features

4-Digit Addressing

Lionel's 2022 Big Book catalog brought tons of new innovations to the world of model trains. One of these new innovations ties together the VISION Class A with the new Base3 and Cab3 App.

TMCC and Legacy engines have always been limited to 2-digit addressing; #1 through #99. The creators of TMCC thought no one would ever possibly need more addresses than that, but Lionel's customer base quickly proved otherwise. Unfortunately, the system was designed, and there was no way to increase the number of digits with the existing radio design.

The need for a new command base has allowed for the introduction of a new Legacy radio that allows for 4-Digit addressing. This new radio in both the Base3 and your VISION Class A allows you to assign an address anywhere from 1 to 9999. Even if you don't have over 100 engines, the 4-Digit system makes it easier to recall your engine. For example, if your Class A's road number is #1218, you can use that as its command address!

For information on how to use the 4-Digit Addressing system, review the Base3's manual online at control.lionel.com.

Controlling your VISION features

BiColor Classification Lights Operation

Legacy Steam locomotives now feature Bicolor Classification or Marker Lights. Using the Cab-2 remote, you can change the color of the lights on the front of the engine from green to white, or off if you choose. Likewise, the marker lights on the rear of the tender can be changed from red to white, or also off.

Note! Not all SKUs are equipped with Classification or Marker lights. Some prototype steam engines did not have these. This section is only for the engines so equipped.

Note! Not all types of steam locomotives will have the bicolor lights. Some railroads, such as Pennsylvania, had Class Lights with different color lenses facing forward vs. facing outward. Those engines will receive a solid color LED with different color lens inserts.

Changing the color of the lights can only be done using a Legacy CAB-2 controller or the CAB3 app. To change the lighting, enter the lighting menu by pressing and holding the Aux2 key.

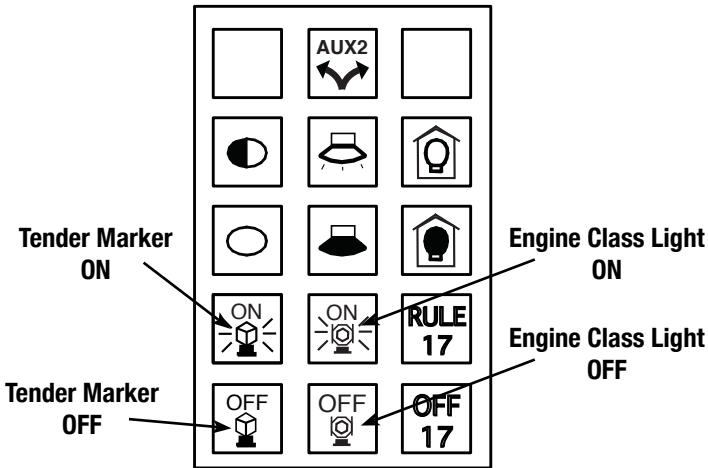

Figure 7. Legacy Steam Engine Lighting Control Menu

1. The classification lights on the front of the locomotive are green by default. Press the “Engine Class Light ON” button once to change the lights to white. Pressing the button again will change back to green.
2. Press the “Engine Class Light OFF” button to turn off the engine class lights.
3. The marker lights on the rear of the tender are red by default. Press the “Tender Marker Light ON” button once to change the lights to white. Pressing the button again will change back to red.
4. Press the “Tender Marker Light OFF” button to turn off the tender marker lights.

Note! The last state of the lights will be stored in the engine’s memory through power cycles. To restore the lights to their default state, follow the reprogramming procedure on page 45.

Note! When operating your engine in Conventional mode, the default color of the lights will be on. BiColor functionality is only available in the Command Control environment.

LEGACY Control System operations

Lash-ups (for LEGACY operations only)

In the Command environment, building a lash-up allows you to control your locomotive as one in a prototypical manner. It is still possible to control any of the engines in the lash-up individually. When you issue a train command, the individual engine you were controlling will return to the group. If there is a difference in speed, the individual Engine will return to the speed of the lash-up at the rate set in the train momentum.

To build a lash-up, assign a unique engine (ENG) ID# to each unit. See page 12 for details.

1. Address the train ID# you wish to create or edit, 1 to 99.
2. Press INFO.
3. Press BUILD softkey (button directly under BUILD).
4. Enter the front engine number. It is not necessary to enter ENG, just enter the #. It will appear in the blinking box.
5. Press ADD to add the front engine. The engine will move to the right and the blinking box will be ready for your next engine to be added.
6. Enter the second engine ID# in the blinking box.
7. Press ADD to add the second engine. The engine will move to the right and the blinking box will be ready for your next engine to be added.
8. Add all the engines you want in your lash-up in this manner.
9. To change the direction of an engine in your lash-up, turn the Velocity Throttle to move the engine you want into the blinking box. Then press DIR to change the direction of the engine.
10. To delete an engine in your lash-up, turn the red Velocity Throttle knob to move the engine you want to delete into the blinking box. Then press DEL.
11. To save your lash-up, press SET. Watch the onscreen prompts and wait until you see the message TRAIN CREATED.
12. Press CTC to exit to the operating screen.

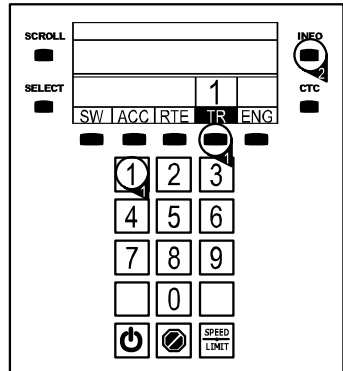

See reference numbers 1 and 2

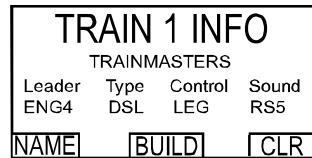

See reference number 3



See reference number 4

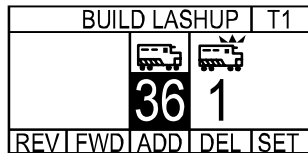

See reference numbers 6 and 7

LEGACY Control System operations

The LEGACY CAB-2 Remote Controller

Main Display

Displays real-time information about your railroad system. Displays real-time feedback of operation.

Scroll Button

Navigates through the entire list of Engines, Trains, Switches, etc.

Select Button

Performs addressing by 3-4 digit road number.

Touch Screen Key Pad

A group of touch sensitive keys with icons for each function. These keys serve many purposes and their icons change accordingly.

Train Brake Slider

This slider is used to increase or decrease the amount of Train Brake affecting the engine or train.

Train Link Button

Quick select of Train-Link devices (LEGACY Control System Version 1.3)

AUX-1/Thru Button

Press to view the Control Panel while operating. Controls switch direction.

Emergency Halt Button

Stops everything on layout; also stops recording playback.

AUX-2/Out Button

Controls switch direction. Toggles all lights on/off, except lights that are wired to track power.

Record Button

Used to record and play back events.

Velocity Throttle

Throttle control over engines, also used to navigate thru info/options.

Set Button

Used to set Engine address and for programming.

Info Button
Used to enter/view the info/options of selected components.

CTC Button

Press and hold to turn your remote on and off. Tap this button to enter the remote and base options. Tap it again to return to the main screen.

Soft Keys

These keys directly correlate to the 5 selection boxes located at the bottom of the main display. These are also used in the info/option menus to select options.

Warning Sound Controller

Warning Bell and Variable Horn control. Pull down to sound Horn. Push up and release to trigger Warning Bell.

Multi Controller

Boost, Brake, and Direction control. Rock forward for Boost, rock backward for engine brake, and press down for direction change. Click-hold-and rock for absolute direction selection.

Front & Rear Coupler Buttons

Fire couplers.

Feedback Button

Toggle ON/OFF the vibration feedback feature in the CAB-2 Remote.

Official R.R. Speed Control Bar

Toggles the touchscreen display of R.R. preset speeds and control panel.

Low, Medium, High Momentum Buttons

Used to select the desired momentum of your addressed engine/train/accessory.

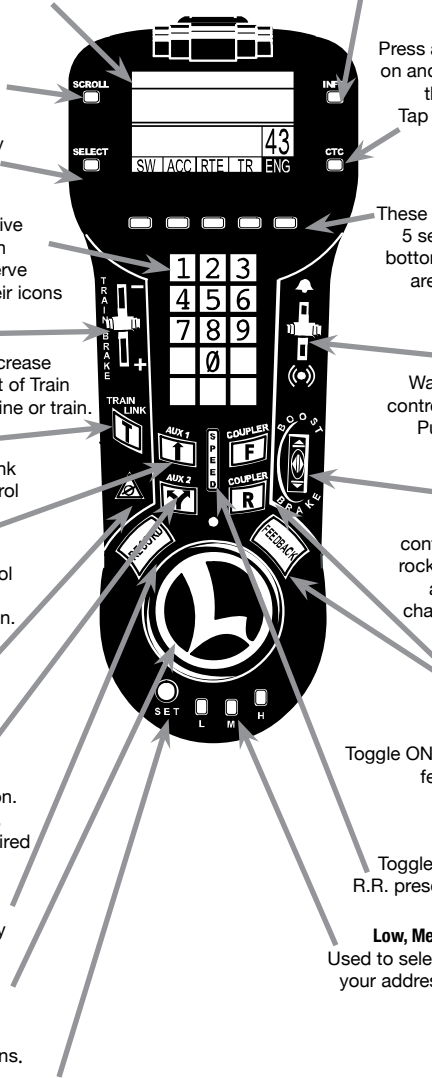

LEGACY Control System operations

Note! This section is a brief overview of the LEGACY Control System. For a more in-depth explanation of the LEGACY Control System features, please see your LEGACY Control System Operations Manual, available online at www.lionel.com.

The Velocity Throttle

The Velocity Throttle (the red rotary knob on the bottom of your Lionel remote) is used to start your engine moving, slow it down, or speed it up. Use it simply by turning it clockwise (speed up) or counter-clockwise (slow down).



The Multi-Controller

Direction

The direction of your engine toggles between forward and reverse at the touch of the Multi-Controller. Press the center of the Multi-Controller once, and your engine's lights will change directions and the engine will stop until you throttle up again in the new direction.

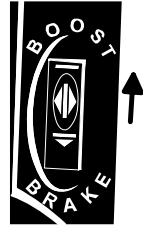

Boost & Brake

Boost and brake give you another way to control the speed of your train. Boost gives your locomotive a temporary increase in tractive power, and returns to the previous speed when you release the control, while the brake command slows you down more quickly than the Velocity Throttle alone.

The Train Brake Slider

The Train Brake is used to slow down and limit the top speed of your train by adding a load. The more the Train Brake is applied by pulling the Train Brake Slider down, the more laboring is heard from the engine. Eventually Train Brake application will slow down the train and it is even possible to stop a train by pulling the Train Brake Slider all the way down. If your smoke unit is turned on, you'll also see more smoke as the slider is pulled down.

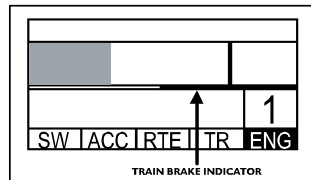
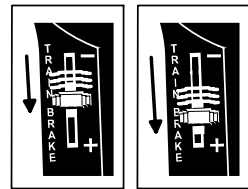

LEGACY Control System operations

The Warning Sound Controller

Warning sounds are an important part of Lionel Railroading. Your Lionel Legacy Control System equipped engines have a real-time variable "quilling" whistle.

Blow the whistle by pulling down on the Warning Sound Controller. Notice the difference in intensity of the whistle sound.

Strike the bell once by pushing the Warning Sound Controller up and releasing quickly. To activate continuous bell sounds, push the Warning Sound Controller up and hold it for 1.5 seconds. To discontinue the bell sounds, push and hold the Warning Sound Controller up until the bell stops.

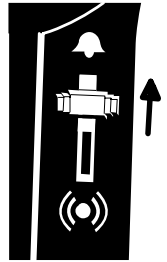

Note! Your engine is equipped with 5 whistles and 5 different pitch levels for the bell! Press Aux1 and pull the Warning Sound Controller down to change the whistle. Press Aux1 and then push the slider up to change the bell pitch.

Note! When changing the whistle, there will be a slight delay between pulling down on the Warning Sound Controller and when you hear the whistle. This is normal.

The Speed Bar

The Speed Bar is used to select a new touch-screen Icon Control set. This set of touch-screen keys is used to select prototypical preset speeds. The speed of the engine changes with each press and release of a different Preset Speed key.

- Tap a key, and your locomotive will immediately begin moving to that speed.
- If you hold the key until the dialog is finished, the engineer will indicate that he is "increasing to...", "slowing to...", or "we are at..." the command speed.

You can also use the Velocity Throttle and other action controls in this mode and continue to use Preset speeds at the same time.

Press **AUX1** to leave the Preset speed mode and return to the Standard Control Panel. Press the speed bar to toggle between the Speed Control Panel and the Standard Control Panel.

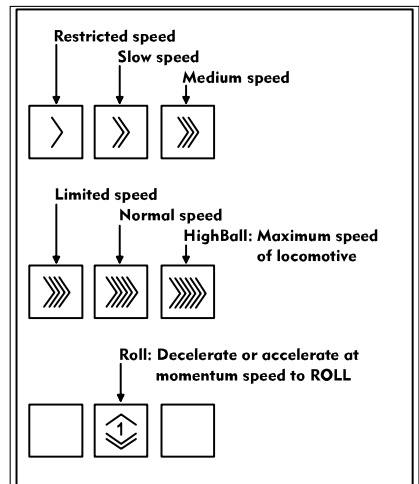

LEGACY Control System operations

EFX Trim and EFX Bar Graph

Sound and smoke effects of the engine can be trimmed higher or lower depending on your operating preference. Pressing the EFX up button will make the engine sound like it is working harder and will also increase the smoke output (if the smoke unit is turned on). Similarly, the EFX down button will decrease the laboring sound of the engine and smoke. A RESET command will return the EFX trim to its default setting.

Notice that the current EFX level is displayed on the remote as a bar graph inside the soft key to the left of the ROLL button. The height of this graph varies with the EFX keys, throttle and train brake adjustments.

Leaving the Preset Speed Screen

Use the Speed Bar to leave the Speed Panel and return to the Control panel. Press the Speed Bar to toggle between the Speed Control Panel and the Standard Control Panel.

LEGACY RailSounds sound system operations

LEGACY RailSounds sound system

Volume UP

Raises the overall master volume of the LEGACY RailSounds sound system. To independently adjust the level of the background sounds only (e.g., the chuffing sounds and steam hiss), tap AUX1 and then this key.

Volume DOWN

Lowers the overall master volume of the LEGACY RailSounds sound system. To independently adjust the level of the background sounds only (e.g., chuffing sounds and steam hiss), tap AUX1 and then this key. Volume settings are retaining when track power is turned off.

TowerCom

Activates dialog of random radio chatter.

CrewTalk

Engineer begins radio dialog, dispatcher replies.

Water Injector/Water Tower

When the engine is in motion, plays the sound of water flowing from the tender to the boiler. When the engine is stopped, plays the sound of the water tower refilling the tender.

RailSounds Shutdown

Activates the LEGACY RailSounds sound system shutdown sequence when stopped.

Emergency Stop

Activates the emergency stop feature while in motion. (Icon will change as the state of the locomotive changes).

Smoke ON

Turns the smoke units ON.

Smoke OFF

Turns the smoke units OFF.

Rule 17 Lighting

Use the Rule 17 buttons to turn the Rule 17 lighting functionality (e.g., headlights dim at a stop) on and off.

Stops and resets the locomotive

Resets the locomotives direction to forward. Press and hold to activate a fueling sequence. Fueling sounds.

Activates pop-off smoke effect

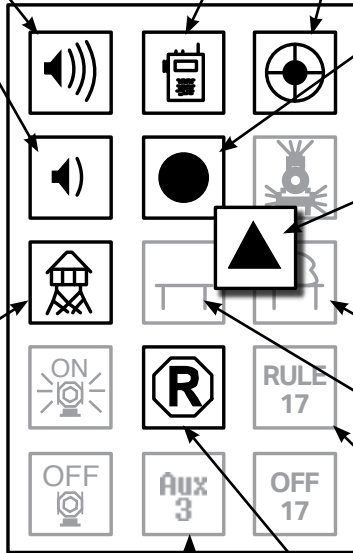

When adjusting the overall volume, you'll hear a single bell hit that gets louder or softer with each volume adjustment. When the volume is at maximum, additional button presses have no effect and won't play the bell. When adjusting the background sounds (AUX1, then a volume key) you'll hear the volume change without a single bell hit.

LEGACY RailSounds sound system operations

LEGACY RailSounds Sequence Control

Your LEGACY-equipped locomotive features Sequence Control. Based on the movement and speed of the locomotive, Sequence Control automatically plays the sound effects of an entire trip, from departure to destination, while you run your locomotive. Prototypical horn signals, bell, and radio chatter are added automatically as you spin your throttle—no need to memorize a sequence of button presses.

To activate the Sequence Control feature, press and hold the **AUX1** button for three seconds. You'll hear a unique bell/horn signal, indicating that Sequence Control is now enabled. Release the **AUX1** key when you hear the sound.

Now, radio chatter, air brake release, and warning signals will play automatically as you move out, reach cruising speed, and then decelerate for arrival, as illustrated in Figure 8. Plus, you can still activate CrewTalk announcements using your remote.

To discontinue Sequence Control, you must tap **AUX1**, and then tap the **0** key or the **RESET** button. Cycling track power off and back on also turns off Sequence Control mode.

Note! During sequence control mode operation, speed step 1 is used to trigger departure effects such as air brake release and departure horn. Therefore your engine will not begin moving until speed step 2 and the Roll Mode button will bring your engine to a stop while Sequence Control mode is enabled. For the most realistic operation, medium or high momentum is recommended when using Sequence Control.

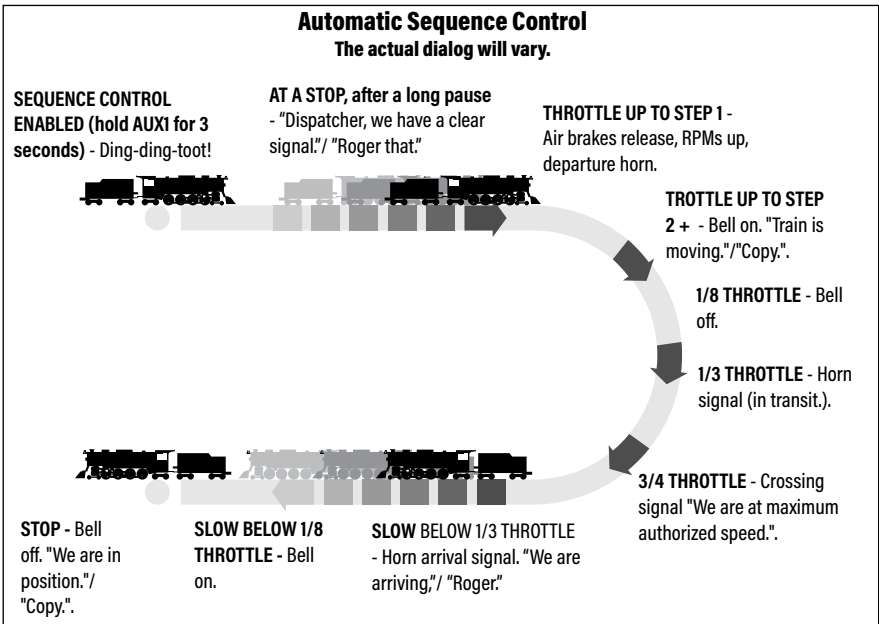

Figure 8. LEGACY RailSounds automatic Sequence Control

LEGACY RailSounds sound system operations

CrewTalk dialog in the LEGACY environment

In addition to the automatic triggering of dialog via Sequence Control mode operation (see the previous section), you may control the dialog manually.

CrewTalk dialog features a variety of brief radio conversations between the engineer and dispatcher. CrewTalk dialog is an engineer-initiated radio conversation with the dispatcher. Be sure to listen for the different combinations of words and phrases that comprise these exchanges.

TrainSounds dialog adds a fun variety to your train's available sounds. In diesels, you'll hear randomized realistic radio chatter. In steam, you'll hear maintenance crews or cab chatter depending on the state of engine.

Refer to Table 1 below for the dialog commands. The dialog in the table provides examples of the conversations you can trigger. The actual dialog will vary.

Locomotive	Commands	Example dialog
Stopped	AUX1, 2	Crew: Fuel level
	2	Crew: Ask to depart Tower: Deny departure
	2	Crew: Ask to depart Tower: Approve departure
	5 or AUX1, 5	Crew: Shutdown Announcement
	Reset or AUX1, 0 (hold for several seconds)	Refueling sequence Crew: My fuel is full
	7	TrainSounds Dialog: Randomized radio chatter
Moving	AUX1, 2	Crew: Report speed
	2	Crew: Are we clear ahead? Tower: Acknowledge
	2	Crew: Are we clear inbound? Tower: Acknowledge
	5 or AUX1, 5	Tower: Emergency stop Crew: Acknowledge
	7	TrainSounds dialog: Randomized radio chatter

Table 1. LEGACY Remote Controller dialog commands

LEGACY RailSounds sound system operations

Dual Sounds

Your VISION Class A is equipped with dual sound systems. The locomotive features a single speaker in the boiler, and the tender boasts two speakers, giving extra bass. The sound systems work in unison to make this engine roar to life!

Many of the sounds will be concentrated to one of the two sound systems, giving a more appropriate location of where that sound comes from. For example, the chuff and whistle sounds primarily come from the locomotive, with reverberated sounds playing in the tender. On the flip side, the sounds of the bell, blowdown, fuel and water loading, and CrewTalk dialog come from the tender.

Another new feature exists with the tender. If the tender goes over a dirty spot on the track and momentarily loses power, the sound system in the tender will restart automatically and pick back up where it left off, like it never even happened!

Using the LionChief App

Note! Available for both Apple and Android small hand-held smart devices.



Connecting your Bluetooth-equipped locomotive on Apple devices

Once you have downloaded the free LionChief app and your locomotive is powered up on the track, tap the LionChief icon on your Apple smart device.

The screens below will be present and within a few seconds will automatically connect with your locomotive. Once it has connected, your Bluetooth enabled locomotive will show up in the locomotive box. You are now ready to operate your locomotive.

Note! A Legacy or LionChief Plus 2.0 Bluetooth-equipped engine will blow the horn/whistle once when it has connected to a Bluetooth device. All others will make a chirping sound until connected.



Figure 9a. LionChief app home screen prior to connecting to an engine



Figure 9b. LionChief app home screen when a locomotive is connected

Using the LionChief App

What if my Bluetooth enabled engine didn't automatically connect?

Tap on the locomotive road number (1234 when no engine is connected). The engine select screen will appear as shown below. Tap on the engine you wish to connect to, and then tap on the Link button to connect. The app will automatically return to the home screen.



Figure 10. Engine Select screen

Using the LionChief App

Connecting your Bluetooth-equipped locomotive on Android devices

Once you have downloaded the free LionChief app and your locomotive is powered up on the track, tap the LionChief icon on your Android smart device.

The home screen below will appear. Tap on the locomotive road number (1234 when no engine is connected). Once on the Engine Select screen, tap on the looking glass icon to search for available engines. Once engines appear, tap on the one you wish to connect to and tap on the link button. Finally, tap on the X button to return to the app home screen.

Note! A Legacy or LionChief Plus 2.0 Bluetooth-equipped engine will blow the horn/whistle once when it has connected to a Bluetooth device. All others will make a chirping sound until connected.



Figure 11a. App home screen prior to connecting to an engine



Figure 11b. Engine Select screen prior to searching for an engine

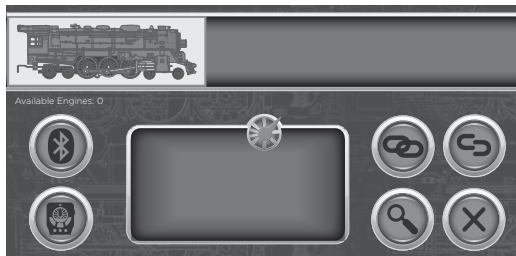

Figure 11c. Engine Select screen after finding an available engine

Using the LionChiefApp

Running your locomotive

This is your main control panel.

Note! Grayed out icons means this feature is not available on your locomotive.

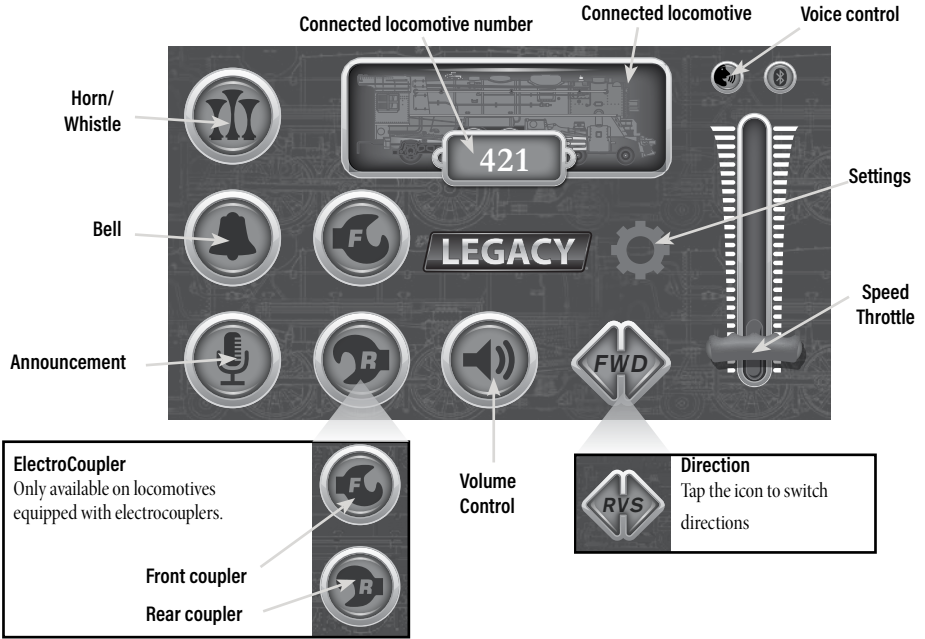

Figure 12. Controlling your locomotive with the app

Using the LionChiefApp

Settings

On the setting screen, you will be able to establish key elements of how your locomotive will run including smoke, momentum and speed limit. These settings will reset once you are done running the locomotive and close out of your LionChief app.

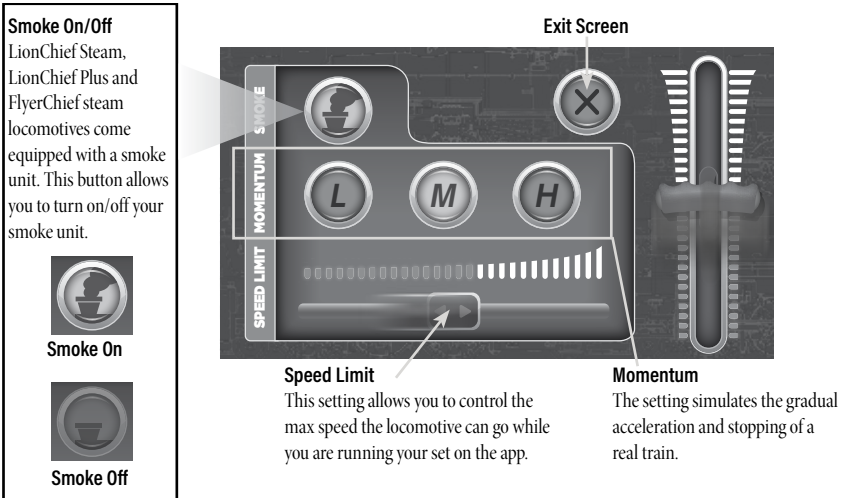

Figure 13. Adjusting locomotive speed and smoke settings

Volume Settings

Lionel Bluetooth-equipped engines come with a very impressive RailSounds sound system. This menu in the app allows you to establish the volume for individual sound elements or the overall sound level.

Note! Once these are established here, the characteristics will continue both on the app or with your remote until you choose to change them again.

Pitch

You are able to adjust the quality of sound "higher" or "lower" for both the horn/whistle and bell.

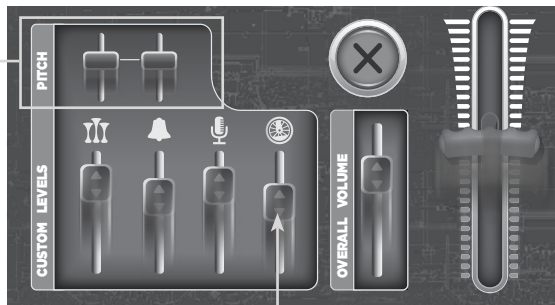

Figure 14. Adjusting locomotive individual and overall volume levels

Note! On newer Legacy models, the horn/whistle pitch slider may change the type of whistle/horn altogether!

Using the LionChief App

Switching Connection Between Multiple Bluetooth® Locomotives

Your LionChief app will display all “available” locomotives in the engine selection carousel. If you have three or more available engines, touch and scroll right to view them. Switching between available locomotives is easy, press the un-link icon to release the currently connected engine. Alternately, you can highlight the engine you would like to run and press the Link icon to connect. In both cases, if the previously selected locomotive was in motion, it will stop when disconnected.

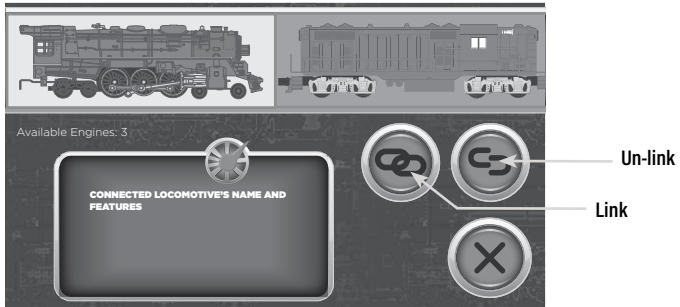

Figure 15. Switching between three locomotives

Using the LionChief App

Lionel Voice Control

The LionChief app now features voice control for Bluetooth-equipped trains! To use voice control, a Bluetooth-equipped engine must first be connected to the app. Once connected and on the app's home screen, tap on the LVC icon as shown below.



Figure 16. LVC button location on the app's home screen

The voice command prompt will appear and indicate that it's ready for you to speak! Try saying different commands to make your engine do as you wish!



Figure 17. Lionel Voice Control prompt

The chart on the next page shows some of the basic commands that the app will recognize. While the app is capable of recognizing many more commands than what is in the chart, this will get you started by using Lionel Voice Control's basic functions.

Using the LionChiefApp

Lionel Voice Control continued

For this feature...	Say these words...
Throttle	
Stop	Stop, Emergency Stop
Slow Speed	Slow Speed, Low Speed, Low Throttle
Medium Speed	Medium Speed, Medium Throttle
Fast Speed	High Speed, Fast Speed, Highball, Full Throttle
Direction change + slow speed	Go Forward, Move forward
Direction change + slow speed	Go Backward, Back Up
Increase Speed	Speed up, Increase speed, Go Faster, Accelerate
Decrease Speed	Slow Down, Decrease Speed, Go Slower, Decelerate
Direction	
Forward	Forward, Forward Direction
Reverse	Reverse, Reverse Direction, Backwards
Toggle	Direction, Change Direction, Other Way, Switch direction
Volume	
Mute	Mute, Volume Off, Quiet
Low Volume	Low Volume, Volume Low, Minimum Volume
Medium Volume	Medium Volume, Volume Medium, Medium Sound
High Volume	High Volume, Max Volume, Full Volume
Dialog	Dialog, Speech, Speak, Talk, Crew Talk
Coupler	
Front Coupler	Front Coupler, Front Connector
Rear Coupler	Rear Coupler, Rear Connector
Bell	
Bell On	Bell On
Bell Off	Bell Off
Horn/Whistle	Horn, Whistle, Blow Horn, Blow Whistle
Smoke	
Smoke on	Smoke On
Smoke off	Smoke Off, No smoke
Other	
Disconnect	Disconnect
Help	Help

Table 2. Lionel Voice Control basic command functions

Note!

If you are trying to figure out more commands to use with Lionel Voice Control, say “help” to the app and an in-app dialog box will appear showing additional available commands.

Using the LionChiefApp

Troubleshooting

- If the locomotive does not appear in the App's "engine selection carousel," try turning the track power off, wait 5 seconds and turn it back on. If that still doesn't work, try restarting the app on your device.
- If a universal remote is present and powered on, make sure one of its 3 channels is not connecting to your locomotive before the app is able to connect.
- Make sure that your smart device's Bluetooth is turned on. This is done outside of the LionChief app.
- If equipped, check the engine's Bluetooth ON/OFF switch and switch it to the ON position.
- For more Voice Control options, say "help" for a list of basic commands.

Note! Legacy and LionChief Plus 2.0 locomotives can receive commands from both a Bluetooth and TMCC controller at the same time.

Using the LionChief Universal Remote

The LionChief Universal Remote (6-83071)

Note!

Please refer to your LionChief Universal Remote manual for in-depth details of operation.

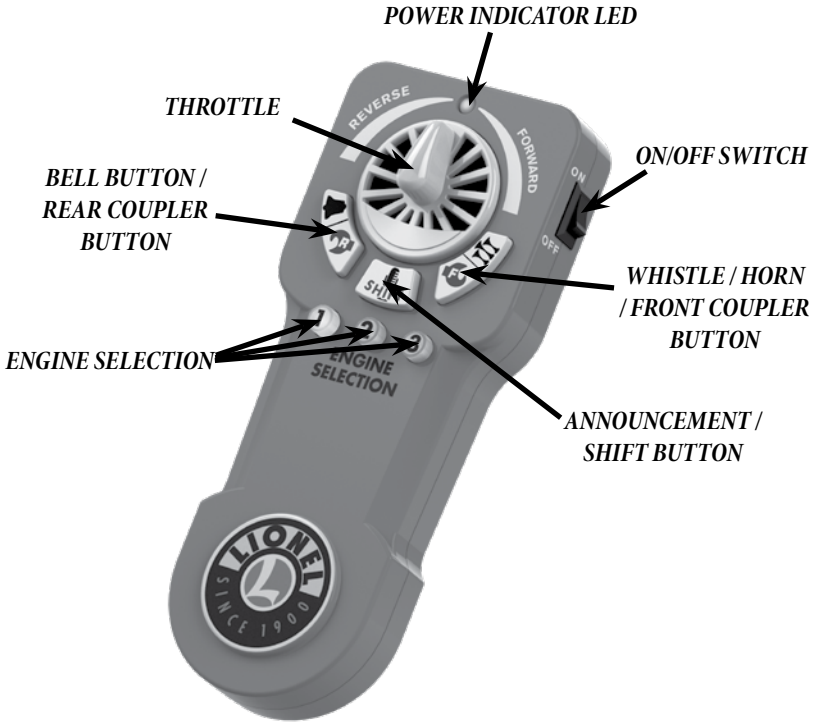

POWER INDICATOR LED

When solidly illuminated, this red LED indicates the remote is turned on. When the remote pairs with a locomotive it will visually reflect the speed on the locomotive; solidly illuminated for idle, slow to fast blink, based on the speed of the locomotive. If the LED does not illuminate when the remote is switched on, the batteries need to be replaced.

ANNOUNCEMENT / SHIFT BUTTON

Press and release the announcement button to activate the locomotive's announcements. Press and hold the Announcement button for it to function as a "shift key".

ON/OFF SWITCH

Use this switch to turn the Universal Remote on and off. We recommend you turn the remote off when not in use to conserve battery life.

Using the LionChief Universal Remote

The LionChief Universal Remote continued

WHISTLE / HORN / FRONT COUPLER BUTTON

Press the Whistle / Horn button to activate the horn / whistle. To activate the front coil coupler on the locomotive press and hold the Announcement button down and, using another finger, press and release the Whistle/Horn button to activate the front coupler. Then release the Announcement/Shift button.

BELL BUTTON / REAR COUPLER BUTTON

To turn the bell on, press the bell button one time. To turn the bell off press the button again. To activate the rear coil coupler on the locomotive press and hold the Announcement button and, using another finger, press and release the Bell button to activate the rear coupler. Then release the Announcement/Shift button.

ENGINE SELECTION

1, 2, 3

Each Engine Selection button represents a channel for controlling one LionChief, LionChief Plus, or Legacy Bluetooth locomotive. Each of these buttons may be “paired” with a different locomotive. Once paired, you can control multiple locomotives from one remote by pressing an Engine Selection button, then using the throttle, horn, bell, etc..

Note! Your remote will remember all locomotive pairings when you turn everything back on for your next operating session.

THROTTLE

Turn the throttle clockwise slowly to increase speed in the forward direction. Returning the throttle to the top dead center position will bring the locomotive to a stop. Moving the throttle counterclockwise will increase the speed of the locomotive in reverse. The Throttle also functions as the volume control for LionChief Plus locomotives. Refer to “Adjusting the locomotive volume” section in this manual for more detailed information.

Using the LionChief Universal Remote

Adjusting the locomotive volume with the Universal Remote

To adjust the overall volume of the locomotive's sound system begin by placing the throttle in the top dead center position (so the red LED is solidly illuminated and the locomotive is stopped). Press and hold the Announcement button then turn the throttle to the left and / or right, this will increase and decrease the overall locomotive volume. Continue holding the Announcement button when turning the throttle, you can stay in this mode until the volume is at the level you desire. Once the volume level is set to the level you want release the Announcement button and return the locomotive throttle to the top dead center position again. (The new volume level will remain until you change it in the future, even after power has been cycled.) If, after running the locomotive, you decide to change the volume, simply follow the steps above to do so.

Note!

If the throttle is not in the top dead center position before or after the volume adjustment process undesired operation will occur. Always start and finish the volume adjustment process with the throttle in the top dead center position!

Pairing locomotives to the Universal Remote

Your Universal Remote can connect or “pair” to one, two or three different locomotives at a time. Each “target” locomotive will be associated with one Engine Selection Button. Once you've paired with a locomotive, you can run it.

However, only “available” locomotives can be paired with the Universal Remote. “Available” means “not currently controlled by any other remote.” An available locomotive will be powered up and beeping or chirping (older LionChief locomotives will play locomotive background sounds when available).

To Pair a Locomotive to Engine Selection button #1

1. Turn on power to your Universal Remote
2. Press and hold Engine Selection button #1 until it blinks rapidly. This will clear any previously stored pairing information so you can connect to the new target locomotive.
3. Release the button. It should flash slowly, indicating it is not connected to a locomotive.
4. Place the target locomotive on the track and apply track power.
5. Tap and release Engine Selection button #1. The remote will now seek and connect to the first available locomotive it finds.
6. Engine Selection button #1 should now be on (no flashing) and if the locomotive was beeping or chirping, it should now be playing engine background sounds.
7. Run the locomotive!

This locomotive pairing is now stored in your Universal Remote. The next time this engine and remote are powered on, the connection will be automatically re-established.

To Pair a Locomotive to Engine Selection buttons 2 or 3, simply follow the same steps with the other two Engine Selection Buttons.

Note!

Legacy locomotives cannot be operated by the Universal Remote if they are already under the control of the App or another Universal Remote.

Using the LionChief Universal Remote

Operating locomotives with the Universal Remote

Now that you have paired locomotives with the Universal Remote its time to run trains! Operation with the Universal Remote is very similar to using the basic remote included with your locomotive. Switch between the locomotives you want to control by pressing different Engine Selection buttons.

Using the Throttle with multiple locomotives

Familiarize yourself with the Universal Remote by putting just one locomotive in motion at a time. Once you are comfortable as to which button is paired to what locomotive, try putting multiple locomotives in motion using the Universal Remote.

As soon as you press a different Engine Selection button, you can command the newly selected engine to blow its whistle, ring the bell or trigger dialog. However, throttle control does not automatically switch!

To take throttle-control of the selected engine, you have two choices: You can make the locomotive match the remote's current throttle position—or—you can change your remote's throttle position to match the engine's current speed and direction.

To immediately force the engine to match the throttle, just press that Engine Selection button a second time. The locomotive will immediately honor the current position of your throttle. This may result in an abrupt change in speed and/or direction.

Option two will avoid the possibility of an abrupt speed change. After pressing the Engine Selection button once, manually turn your throttle knob until it matches the locomotive's current speed and direction. Once you've matched the knob position, the main red LED will begin flashing at a rate proportional to the engine's speed. From this point on, further throttle rotation will change the engine's speed and/or direction.

Here's an example showing the "throttle matching" option in action.

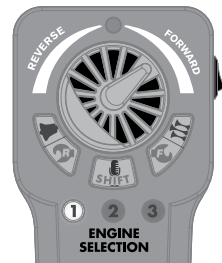

Engine #1 (above) is a diesel with throttle set for forward direction, medium speed.

Using the LionChief Universal Remote

Operating locomotives with the Universal Remote continued

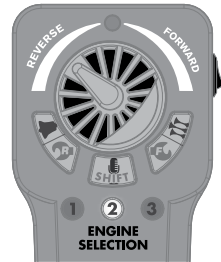

Engine 2 (above) is a steamer at stop. Press Engine Selection button #2 and turn the throttle counter-clockwise through the 12 o'clock (stop) position and continue to put this loco in reverse at slow speed. Meanwhile, notice that engine #1 is still moving forward as before.

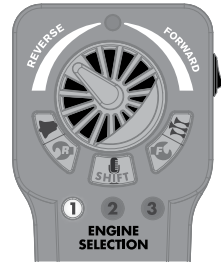

Now, switch back to engine #1, the diesel. Note that even though the throttle is in the reverse/slow speed position, the diesel continues moving forward at medium speed.

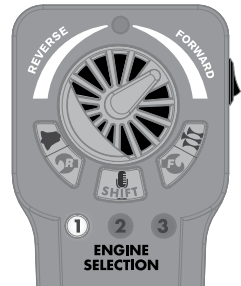
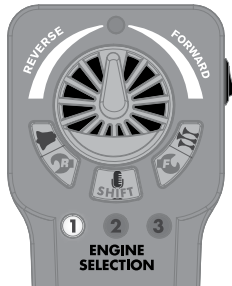
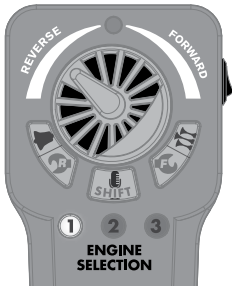

Match!

To regain speed and direction control over diesel locomotive #1, you must match the throttle position to the engine's current speed and direction. Turn the throttle clockwise. Once you've matched the throttle position, additional throttle adjustments will again cause speed and direction changes of the currently selected engine.

TrainMaster Command Control operations

CAB-1 Remote Controller commands

The CAB-1 Remote Controller commands are detailed below. The corresponding RailSounds sound system effects are in italic type.



Releases the ElectroCoupler on the front of the locomotive. *Coupler release sound.*



Releases the ElectroCoupler on the rear of the locomotive. *Coupler release sound.*



Activates the numeric keypad. *Short air release sound.*



Controls switch direction. Toggles all lights on/off, except lights that are wired to track power.



Accelerates the locomotive with a clockwise rotation. Decelerates the locomotive with a counter-clockwise rotation. *Speed-dependent RPM sounds.*



Activates the locomotive's horn. Release the button to discontinue the sound. *Horn sound.*



Toggles the bell sound on and off. *Bell sound.*



Changes the locomotive's direction. The locomotive decelerates to a stop and continues in the opposite direction when you increase the throttle. *Air release sound.*



Increases the locomotive's speed while the button is pressed. Release the button to return to the initial speed. *Labored prime mover.*



Decreases the locomotive's speed while the button is pressed. *Squealing brake sounds.*



Shuts down all PowerMasters on your railroad. Stops all TrainMaster Command Control-equipped locomotives in operation. Use HALT only in emergency situations.



Odyssey II Momentum

- L** 32 speed steps with low momentum
- M** 100 speed steps with low momentum
- H** 100 speed steps with medium momentum

TrainMaster Command Control operations

CAB-1 Remote Controller numeric keypad commands

When you press the AUX1 button on your CAB-1 Remote Controller, you turn the numeric keypad into ten command buttons. After you press the AUX1 button, you will be able to press any numbered button until you address a different product. *The corresponding RailSounds sound system effects are in italic type.*



Stops and resets the locomotive. Resets the locomotive's direction to forward. Your locomotive keeps track of its fuel level. Higher engine speeds and/or heavy labor will use fuel at a faster rate. Press and hold **AUX1, 0** for at least 3 seconds. You will hear the sounds of fuel being loaded into the tender as long as you hold the button. When you release the button, the sounds will stop and the engineer will confirm that the fuel is full. *Refueling sequence.*



Raises the overall master volume of the LEGACY RailSounds sound system. To independently adjust the level of the background sounds only (e.g., the diesel roar and brake sounds), tap **AUX1** and then this key. *Sound volume increases.*

When adjusting the overall volume, you'll hear a single bell hit that gets louder or softer with each volume adjustment. When the volume is at maximum, additional button presses have no effect and won't play the bell. When adjusting the background sounds (**AUX1**, then a volume key) you'll hear the chuff volume change without a single bell hit.



Engineer begins radio dialog, dispatcher replies (see page 25). *CrewTalk communication.*



In motion, plays the sound of the injector transferring water from the tender to the boiler. At a stop, plays the sound of a water tower spigot arm lowering, then water gushing from the tower into the tender, which also "refills" the virtual water level in the tender and plays a confirming radio dialog. *Water injector/water tower sounds.*

TrainMaster Command Control operations

CAB-1 Remote Controller numeric keypad commands (continued)



Lowers the overall master volume of the LEGACY RailSounds sound system. To independently adjust the level of the background sounds only (e.g., chuffing and steam hiss), tap **AUX1** and then this key. Volume settings are retained when track power is turned off. *Sound volume decreases.*



Activates the LEGACY RailSounds sound system shutdown sequence when stopped. Activates the emergency stop feature while in motion. Note that, in the shutdown sequence, the smoke unit will turn off if it was already on.



Triggers the blowdown sound.



TrainSounds random radio chatter.



Turns off the smoke units. *Let-off sound.*



Turns on the smoke unit if the smoke unit switch is in the ON position. Be sure to add smoke fluid before turning on the smoke unit to prevent damage to your locomotive. *Air release sound.*

Note! 8 and 9 function only if the locomotive's smoke unit switch is in the ON position.

Setting the smoke level

You may adjust the level of smoke production using your Remote. Use the sequences below.

If the smoke unit is off, press the **9** key to turn the smoke unit on for **LOW** smoke production. Press again for **MEDIUM** smoke, and lastly one more press for **HIGH** smoke production. The **8** key can then be used to turn the smoke production back down and then off.

Conventional transformer operations

Using the LEGACY RailSounds sound system in the conventional environment

When you first power up your locomotive, you will hear the sounds of the locomotive at rest. As the locomotive moves, the chuff sounds automatically increase with the locomotive's speed. In the conventional environment, the whistle and bell sounds are activated by your transformer controls, if so equipped.

In the conventional environment, you will experience several features of the LEGACY RailSounds sound system.

- **DynaChuff.** Your locomotive's speed automatically determines the character of the chuffing sounds. At low speeds, the chuffing sounds are longer. When you highball down the mainline, the chuffing intensity becomes more percussive.
- **MultiWhistle.** A different whistle sound at different speeds.
- **Mechanical bell.** Press BELL on your transformer to begin the effect, then press BELL a second time to discontinue the effect.
- **CrewTalk dialog.** These brief conversations between the train crew and the tower are triggered by short horn blasts.

Note! When operating in Conventional mode, the overall volume of the RailSounds sound system is slightly reduced. For full volume, the engine must be controlled with a Legacy or Bluetooth controller.

Locking your locomotive into a single direction

When the program-run switch is in the RUN position, your locomotive sequences through a repeating pattern of operations: forward, neutral, reverse, neutral, and so on.

To "lock" your locomotive into a single direction (for example, to operate in forward only), you can deactivate the Command reverse unit's sequencing function.

1. **Use your transformer's DIRECTION button or interruptions in track power to get your locomotive moving slowly in the desired direction or into neutral.**
2. **Slide the program-run switch on the powered unit to the PGM position. At this point, the locomotive is "locked" into your chosen direction. See Figure 4 on page 9 for the location of this switch.**

To restore the forward-neutral-reverse sequence, just slide the program-run switch back to the RUN position.

Maintaining and servicing your locomotive

Reprogramming your locomotive to restore features

If your locomotive is unresponsive to your commands in the Command Control environment, we recommend that you follow this procedure to reset your locomotive. All factory default settings will be restored when you reprogram the locomotive.

1. **Slide the program-run switch to the PGM position.**
2. **Plug in and connect your LEGACY Base.**
3. **Place your locomotive and tender on the track, then power up the track.**
4. **Press ENG and enter the locomotive's ID#.**
5. **Press SET.**
6. **Press and hold the RESET button (or 0) until you hear a single bell ding. This may take up to 10 seconds.**
7. **At this point, your locomotive has been reset to ID 1. Be sure to re-enter your original ID# and press SET once more if you wish to continue using your original ID#.**
8. **Slide the program-run switch back to the RUN position and operate the locomotive as usual.**

Maintaining and servicing your locomotive

Lubricating your locomotive and tender

Help your Lionel locomotive lead a long and productive life on your railroad by maintaining it properly. To keep your locomotive lubricated, we recommend that you purchase a Lionel Lubrication and Maintenance Kit (6-62927), available from your authorized Lionel dealer.

When you find that the lubrication points illustrated in Figure 18 appear dry, lubricate your locomotive after you have removed any accumulated dirt and dust. There are two basic rules to keep in mind when you are lubricating your locomotive: use only a small amount of lubrication and avoid getting grease or oil on your locomotive's wheels, roller pick-ups, or the track.

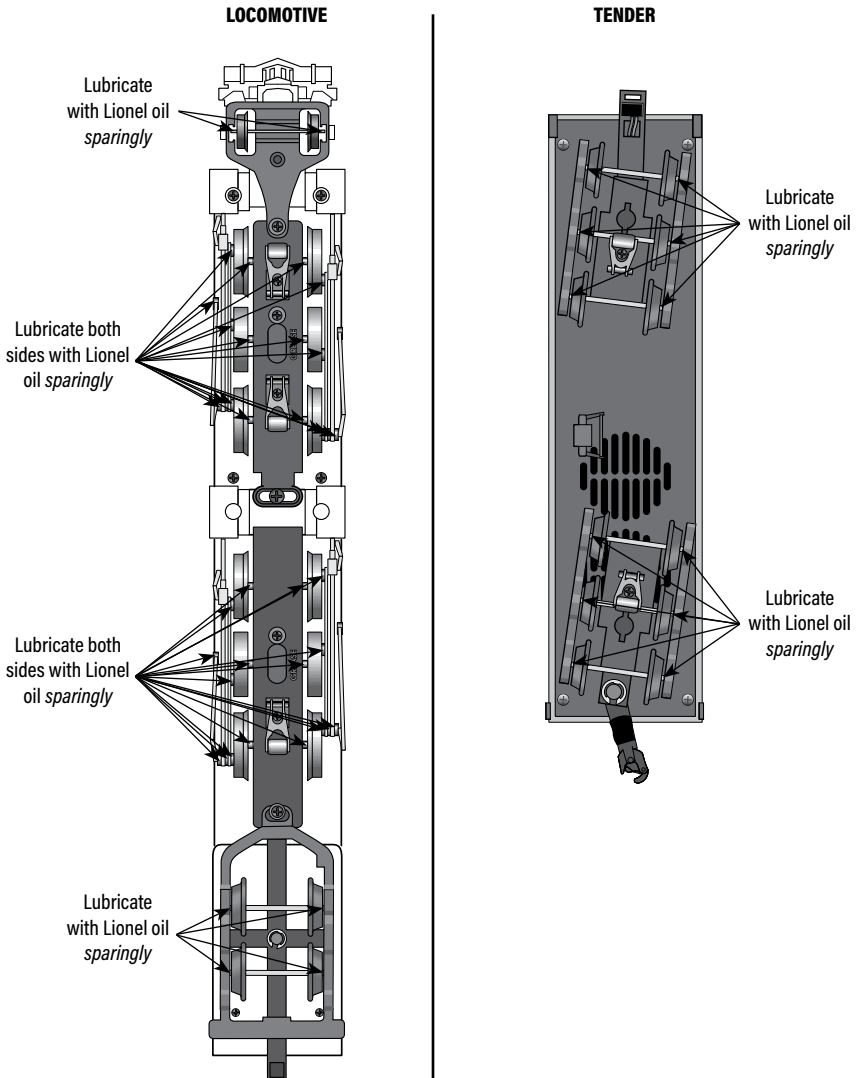

Figure 18. Locomotive and tender underside details and lubrication points

Maintaining and servicing your locomotive

Servicing your locomotive's LEDs

Note! If the locomotive is powered up and the lights are not on, check that the **AUX2** command was not used to turn the lamps off.

Your locomotive is illuminated by several LEDs that are expected to last for the life of the locomotive. The LEDs are not user serviceable. If service is required, we recommend that you have your locomotive serviced at a Lionel Factory Trained Authorized Service Station or Lionel Service.

Replacing the traction tires

Your Legacy Steam Locomotive is equipped with traction tires. This means that some of the drive wheels are fitted with rubber traction tires to enhance tractive effort so your locomotive can pull many cars at once.

Lionel has provided extra traction tires to replace the installed traction tires if they ever wear out. The traction tires are replaced by unscrewing the drive rod screws using the supplied wrench or with a Phillip's head screwdriver. See Figure 19. Slip off the old traction tire and remove it from under the drive rod. Place the new traction tire on the wheel and re-tighten the drive rod screw.

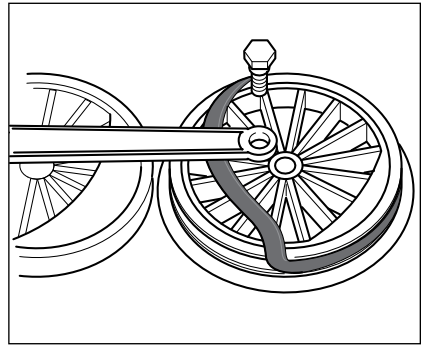

Figure 19. Replacing traction tires

Locomotive diagnostics

Your locomotive includes built-in diagnostics to monitor the condition of the main drive motor. If a problem is detected, the locomotive's cab light will blink a diagnostic code.

If you see the light inside the cab flashing, press **RESET** (for LEGACY operation), **0** (for TMCC operation), or **DIRECTION**/power interruption (for conventional operation) to attempt to clear the problem. The locomotive will immediately check itself again. If the problem persists, the cab light will blink the code again.

Number of Blinks	Diagnostic Code Description
1	Main drive motor stalled.

Lionel Limited Warranty Policy & Service

This Lionel product, including all mechanical and electrical components, moving parts, motors and structural components, with the exception of **TRACTION TIRES** are warranted to the original owner-purchaser for a period of **one year from the original date of purchase** against original defects in materials or workmanship when purchased through a **Lionel Authorized Retailer***.

This warranty does **NOT** cover the following:

- Normal wear and tear
- Defects appearing in the course of commercial use
- Damage resulting from abuse/misuse of the product
- Damage resulting from consumer or unauthorized attempted repair or modification

Transfer of this product by the original owner-purchaser to another person voids this warranty in its entirety. Modification of this product in any way; visually, mechanically or electronically, voids the warranty in its entirety.

Any warranted product which is defective in original materials or workmanship and is delivered by the **original owner-purchaser** (this warranty is non-transferrable) to Lionel LLC **MUST** be accompanied by the original receipt for purchase (or copy) from an **Authorized Lionel Retailer***, will at the discretion of Lionel LLC, be repaired or replaced, without charge for parts or labor. In the event the defective product cannot be repaired, and a suitable replacement is not available, Lionel will offer to replace the product with a comparable model (**determined by Lionel LLC**), if available. In the event a comparable model is not available the customer will be refunded the original purchase price (requires proof of purchase from the **Authorized Lionel Retailer*** it was originally purchased). Any products on which warranty service is sought must be sent with prior Return Authorization # from Lionel freight or postage prepaid (Lionel will refuse any package when postage is due). Lionel is not responsible for any unauthorized contents of the package or shipping packaging or materials or any package sent without prior authorization. **Transportation and shipping charges are not covered as part of this warranty for international shipments.**

NOTE: Products that require service that do not have a receipt will not be serviced by Lionel. Any product sent to Lionel under a Return Authorization and not accompanied by a receipt; the return shipping costs will be the responsibility of the customer.

In no event shall Lionel LLC be held liable for incidental or consequential damages.

Some states do not allow the exclusion or limitation of incidental or consequential damages, so the above exclusion may not apply to you. This warranty gives you specific legal rights and you may have other rights which vary from state to state.

Instructions for Obtaining Service

If service for this Lionel LLC product is required you must **FIRST** call 1-800-4LIONEL (1-800-454-6635), Email Talktous@lionel.com, or write to Lionel Customer Service, 6301 Performance Drive, Concord, NC 28027. Please have the Lionel product number and original receipt showing the date, location of original purchase, and description of problem. You will receive a return authorization (RA) number to ensure your merchandise will be properly tracked and handled upon receipt at Lionel LLC.

Once you have your Return Authorization (RA) number, make sure the item is well packed to protect during shipping. (The original packaging was designed to protect product during transit).

Please make sure you have followed all of the above instructions carefully before returning any merchandise for service.

Warranty Information

Products that are more than 3 years old, from date of manufacture, are not applicable for warranty coverage, even if they have never been sold prior to this date. (Under no circumstance shall any components or labor be provided free of charge.)



©2022 LIONEL L.L.C.
6301 Performance Dr., CONCORD, NC 28027
UNITED STATES OF AMERICA
PRINTED IN CHINA